

### Y-Type and Block-Type strainers protect pumps, divider valves, and lubrication equipment.

#### DESCRIPTION

These Trabon strainers are simple, compact, durable and feature readily removable, cleanable, and replaceable filtering screens.

Easily installed in new or existing lubrication systems, they can protect the entire system including the pump

against contaminants. If they are utilized to protect the entire system, they should be located at the reservoir fill point. In this case, pressure filling will be required. If a strainer is to protect only the divider valve, it should be installed just downstream of the pump discharge.

#### STEEL BLOCK STRAINER

Rated pressure ..... 7,500 psi (517.12 Bars)  
 Thread size ..... 1/4 inch female pipe  
 Net weight (approx.) ..... 3lb. (1.36 kg.)

##### Order Part No.

Strainer with 100-mesh screen ..... 527-100-380  
 Replacement screen for above ..... 525-766-010  
 Strainer with 325-mesh screen ..... 527-100-390  
 Replacement screen for above ..... 525-766-015

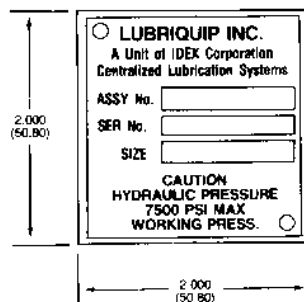
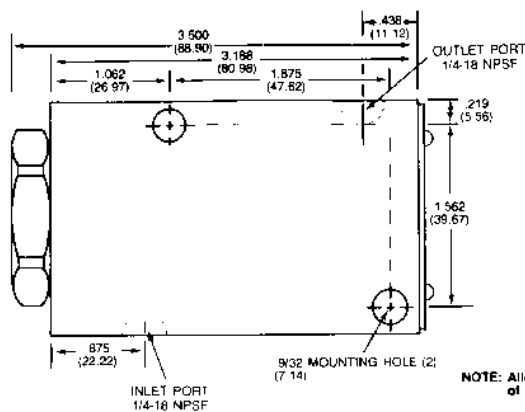
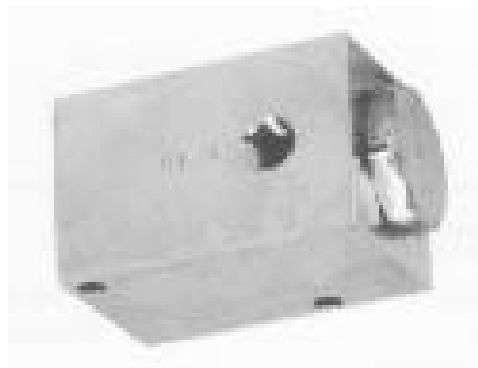

NOTE: Allow approximately 3 in. clearance for removal of filter element.

#### STEEL BLOCK STRAINER

Rated pressure ..... 2,000 psi (137.9 Bars)  
 Thread size ..... 1/4 inch female pipe  
 Net weight ..... .625 lb. (.283 kg.)

##### Order Part No.

Block strainer with 40-mesh screen ..... 500-585-001  
 Replacement screen for above ..... 529-093-000

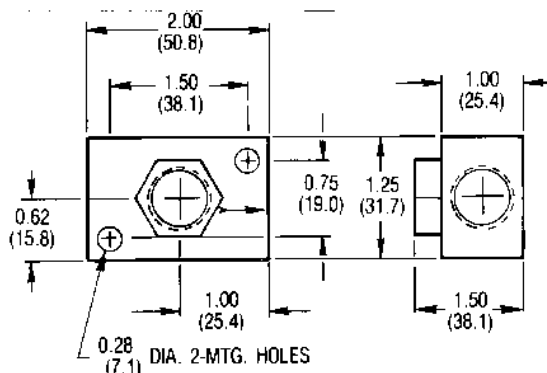

**FILL POINT STRAINER  
(with removable element)**

Rated Pressure ..... 3,000 psi  
 Thread size ..... 1/4 NPT  
 Net weight (approx.) ..... 2 oz. (.057 kg.)

**Order Part No.**

Strainer with 100-mesh screen ..... 473-020-468  
 Replacement screen for above ..... 473-020-465  
 Strainer with 325-mesh screen ..... 473-020-469  
 Replacement screen for above ..... 473-020-466

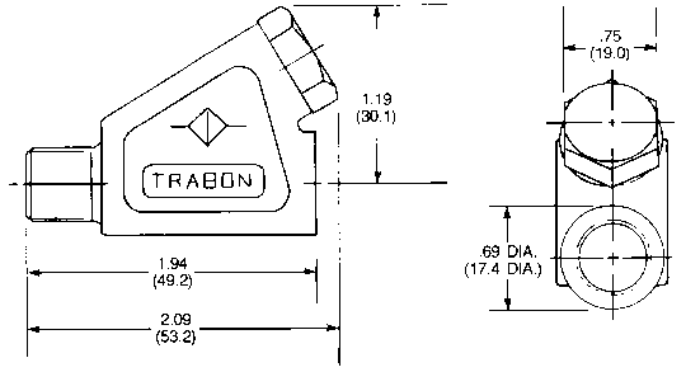

**CAST STEEL Y STRAINER**

Rated pressure ..... 1,500 psi (103.43 Bars)  
 Thread size ..... 1/2 inch female pipe  
 Net weight (approx.) ..... 1.13 lb. (.513 kg.)

**Order Part No.**

Strainer with 20-mesh screen ..... 506-942-000  
 Replacement screen for above ..... 506-993-000

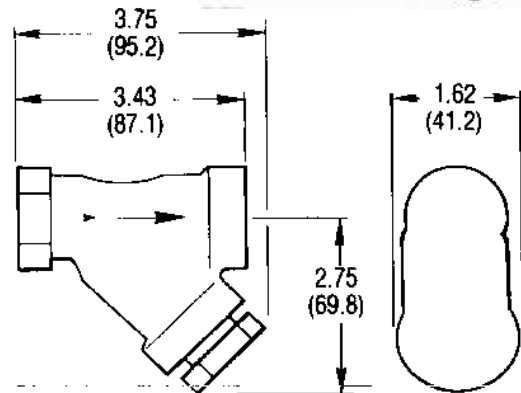

**LUBRIQUIP**<sup>®</sup>  
 Centralized Lubrication Systems

® Registered trademarks of LUBRIQUIP, INC.,  
 A Unit of IDEX Corporation.