

## INTRODUCTION

The Lube Sentinel II is a field configurable micro-processor based monitor, capable of detecting low and high flow variations in any Series-Progressive type lubrication system regardless of manufacturer. This system-dedicated device can compute and monitor precise lubrication rates in increments of 0.001 in<sup>3</sup>, to a minimum of 0.005 in<sup>3</sup> per lube cycle.

Programming is simple with the easy-to-use, three-button design. No computer knowledge or special training is necessary. No jumper wires or external equipment is required. Programming involves inputting parameters and selecting options as prompted by the LCD (Liquid Crystal Display).

The Lube Sentinel II is available in both **JIC** and **Explosion-Proof Enclosures**, or without an enclosure but with appropriate mounting hardware for use in a pre-existing Sentinel I enclosure.

The unit may be configured for either **single** or **dual zone** operation, but only active zones are displayed. (Either Zone 1, Zone 2, or both may be displayed.) Zones can be programmed as inactive, or can be temporarily disabled by process control using a contact closure.

Three modes of display are selectable:

(1) instantaneous, (2) average or (3) total. Modes of display cannot be mixed between zones. Six units of measure are selectable: pints, gallons, milliliters, liters, ounces, or counts. Units of measure can be mixed between zones.

An optional plug-in, "**Safety Set Kit**," allows reset, programming and the selection of display options from outside of the enclosure, precluding the need to open the enclosure to press the buttons. Three sensors replicate the three function buttons, and are activated by covering and uncovering the target area with a special magnet. To prevent unauthorized adjustment of setpoints and preset values, a "Safety Set" sensor can be permanently disabled, thus allowing only the ability to change the display mode and affect a system reset.

Status of the lubrication system is monitored through fault relays. The relays may be programmed to energize either in normal or in fault conditions. A special transistor output is provided to monitor (echo) each zone cycle sensor and system fault. This output may be connected directly to a PLC or other solid-state control device.

The Lube Sentinel II Monitor is equipped with **serial communication capability**. Communication through



this serial port allows for monitoring and programming of the controller by a remote computer using alphanumeric messages. Connection to this port is made using three wires via a special 6-pin header connector, using RS-232 signaling levels.

The unit can be programmed to register a fault after one, two, or three consecutive apparent faults.

As machine speeds change, fault times and rates can be automatically proportioned using a tach pulse sensor (not provided).

The Sentinel II may be powered by 115 or 230 VAC (50/60 Hz) or by 24 VDC. A 24 VDC output is available for powering field sensors if needed, via two internal terminals.

## NORMAL OPERATION (Monitor)

Operation of the Lube Sentinel II is controlled through the use of three buttons located on the front display panel. They are labeled: **RST/CLR** (reset and/or clear), **SLCT** (select), and **PRGM** (program). Once the Lube Sentinel II has been programmed (refer to instructions in this bulletin), it is ready for normal operation, also referred to as the monitor mode. In this mode, the Sentinel II monitors the lubricant delivery and provides appropriate data on the LCD display and on the LEDs.

There are three LEDs per zone for quick visual status reporting. The red LED is lit any time a zone is in fault. The green LED is lit if a zone has its alarms active and system is normal. Absence of either red or green lit LEDs indicates that associated zone alarms are disabled. The yellow LED echoes the cycle switch sensor status and is lit when the switch is closed.

The LCD typically displays information in one of three ways. Any of the three ways can be selected by pressing the **SLCT** (select) button. The LCD displays letter codes to identify the chosen display.

**I (Instantaneous)** - This selection displays the lube displacement (per 24 hours) based on the time interval between the last two cycles of the divider valve. This time and the amount of lube delivered by one cycle of the divider valve are factored together to determine the 24-hour displacement.

**A (Average)** - This selection displays the lube displacement (per 24 hours) based on the amount of time required to complete ten cycles of the divider valve.

**T (Total)** - This selection displays the total amount of lubricant that has been displaced. The value is determined by multiplication of the divider valve delivery by the number of times the valve has been cycled. This number is automatically stored in memory upon completion of every ten minutes of operation.

## Tachometer Information

A fourth sub-selection displays actual engine/compressor shaft speed (rpm) along with a flashing asterisk designating shaft encoder contact closure, if the tachometer is enabled. Note that the asterisk rate of flash will track the input up to 120 pulses per minute. Inputs faster than 120 ppm will result in the correct rpm being monitored and displayed, but the asterisk flash will not be shown. Additionally, a second LCD line displays the normal target operating speed. Variation of actual speed from target speed adjusts fault rates proportionately to +/-50% maximum correction. An ON/OFF indication is displayed to indicate when alarm monitoring is active.

With the tachometer enabled and the drive mechanism operating at minimal speed, it is possible to override the active alarms by pressing the **RST/CLR** and preclude all alarms until the machine accelerates to 50% of its normal operating speed. At that point, the alarm override ceases, allowing proportional alarmed startup of the equipment. Enabled alarms stay active through all ranges of input rpm until they are manually reset once again after the machine has decelerated from 50% of its normal operating speed. Note that when the alarm override is active, a letter "T" and the word "OFF" will be displayed on the LCD.

If the Sentinel II senses a fault, it may be reset by pressing the **RST/CLR** (reset) button. Notice that when the **RST/CLR** button is pressed, the display is reset back to zero. If the display is in the totalized mode (identified by letter T), pressing **RST/CLR** will reset the totals back to the last stored value. Care should be exercised when resetting a fault to ensure that the display is not in the totalized mode as resetting the fault will also reset the total accumulated usage. It is for this reason that whenever power is applied to the Sentinel II or a return to the monitor mode is done, the display defaults to the instantaneous mode.

## Zone Enable/Disable

Zones are enabled during programming. A zone may be disabled initially by programming the zone "off" or by temporarily placing an enabled zone in a "bypass" mode. Closing the contacts for "zone bypass" disables a zone from any fault time-outs, and the zone display shows the word "BYPASS" to indicate this condition. When the bypass has been removed, active monitoring of the zone continues, and if the alarm is enabled, the alarm time-out will restart.

## Fault Relay Information

There are three fault relays, one is used as a power monitor and two are used as zone fault relays. The power monitor relay is a single-pole, double-throw relay with Form C contacts. It energizes about five seconds after power is applied and stays energized as long as power is available to the monitor. When power is removed from the system, the relay deenergizes immediately. Zone fault relays are enabled during programming. Each zone fault relay is a double-pole, double-throw relay with two Form C contacts that change state when their associated zone goes into fault. The zone fault relay may be programmed to either pick or drop when a fault is detected, thus allowing for fail-safe operation if desired. A system fault TTL output is also available to annunciate faults. It is also linked with the programming for the relay energization settings.

Faults may be reset in several ways; they may be manually reset at the monitor by pressing the **RST/CLR** button or by using the paralleled "Safety Set" target; they may be reset electrically by closing the remote reset contacts; and they may be reset via command through the serial port (see Serial Communications for details).

## Cycle Switches and Other Sensor Inputs

All sensor inputs should be dry contact types. Each input uses 10 milliamps nominal drive at 24 VDC. Some 2-wire solid-state sensors may be used. 3-wire solid-state sensors may be used with some considerations. Refer to Drawing on page 10 for more information on hookup.

Cycle switch TTL outputs are provided for each zone to echo the status of the sensor input from the divider valve or other device. The output conducts current when the sensor contacts are open. When the sensor contacts close, the output shuts off. (Note that these outputs should not be used for cycle rates faster than one pulse per second. Output pulses may be missed if higher rates are used.) These outputs are not short-circuit protected (100 mA max.), so use care when connecting them. Improper connection could result in permanent damage to these outputs. Refer to Circuit Board Connections on page 7 for further details.

## PROGRAMMING OVERVIEW

### Entering Data

There are four main selections within the programming field. These are:

- **CONFIGURATION? ZONE 1:** This allows the programmer to set the parameters for Zone 1.
- **CONFIGURATION? ZONE 2:** This allows the programmer to set the parameters for Zone 2.
- **SERIAL PORT:** This allows the programmer to set the parameters needed for serial communications to a PC.
- **GLOBAL SETTINGS:** This allows the programmer to specify how the monitor reacts to faults and how relays are energized or deenergized.

Refer to Figure 1.

1. Pressing the **PRGM** button once places the Sentinel II in the programming field.
2. Pressing the **SLCT** button moves from field CON-

FIGURATION? ZONE 1, to CONFIGURATION? ZONE 2, to SERIAL PORT, and to GLOBAL SETTINGS.

3. Once the programmer is at the desired field, pressing the **PRGM** button scrolls through the options within that field.
4. Pressing the **SLCT** button toggles through the choices available for the selected option.

Refer to the Step-by-Step Programming Instructions on page 4 for complete descriptions.

### Saving Program Changes

When the display shows CONFIGURATION? ZONE 1, (or ZONE 2), SERIAL PORT or GLOBAL SETTINGS, press the **RST/CLR** button to place the Sentinel II in the monitor mode. A prompt will ask if any changes should be saved. The default is NO. To save any changes, press the **SLCT** button to change to YES, and then press the **PRGM** button. Pressing any other button when NO is showing will erase any changes indicated and leave all settings as they were before entering the programming function.

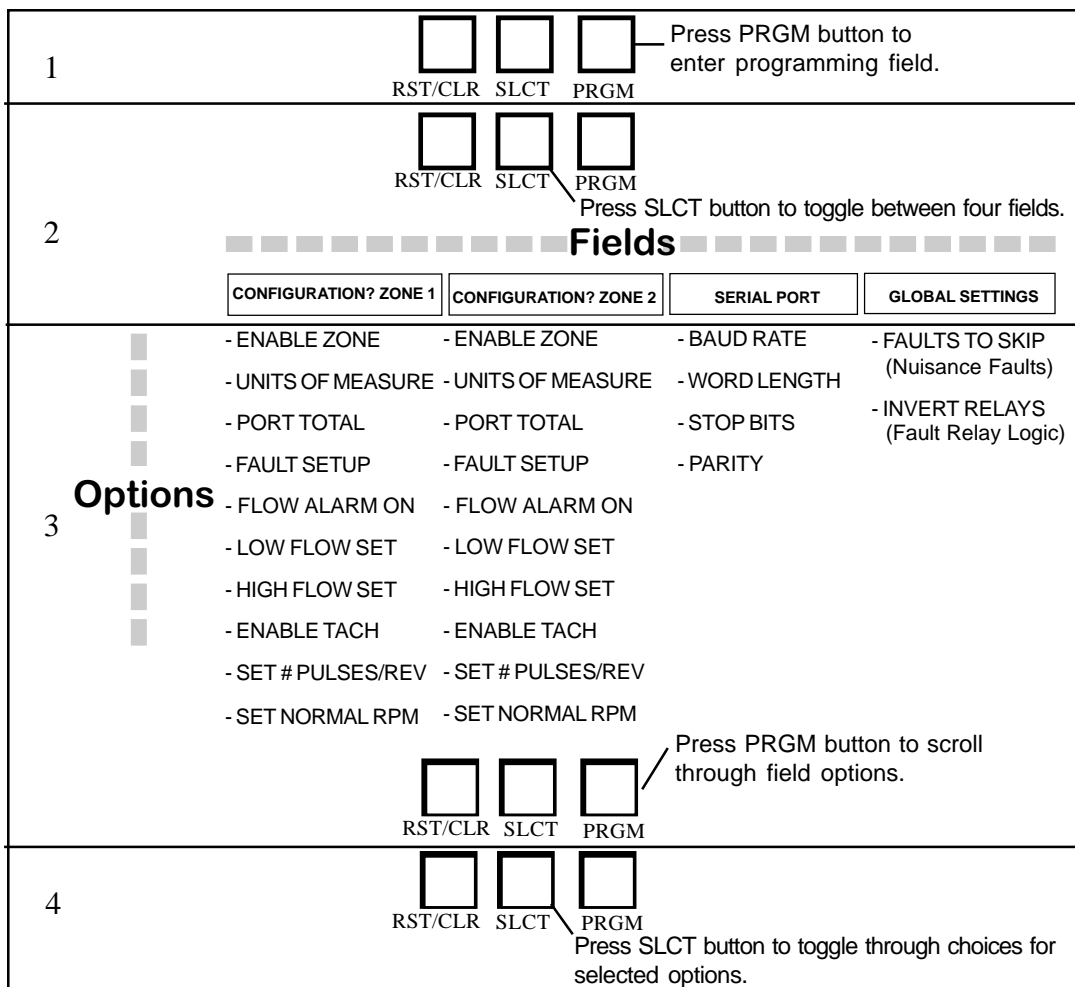

Figure 1. Programming Overview

## STEP-BY-STEP PROGRAMMING INSTRUCTIONS

### General

As mentioned in Program Overview, once the programming mode is entered (by pressing the PRGM button) there are four selections the programmer can go to. This discussion provides complete instructions of each selection in order of appearance. If desired, the programmer can proceed to the desired selection by pressing the SLCT button until the desired selection is shown.

### Configuration? Zone 1

Enter the programming mode by pressing the PRGM button. The display will show CONFIGURATION? ZONE 1.

With the display showing CONFIGURATION? ZONE 1, press the **PRGM** button to enter the options for Zone 1. The options are listed below:

**Enable Zone:** The first option will be to enable the zone. Pressing the **SLCT** button toggles between YES and NO. If the zone is not to be enabled, no further options will be asked for. A disabled zone appears as dashes across the screen and will not generate any faults.

Press the **PRGM** button again to advance to the next programming option.

**Units of Measure:** Pressing the **SLCT** button toggles between the displayable units: ounces, pints, gallons, liters, milliliters, or counts. Choosing one of these units will be reflected on the display. It is possible to have each zone read out in different units.

Press the **PRGM** button to advance to the next programming option.

**Port Total:** The total quantity of lubricant volume being provided to lubrication points will be asked for next. This input is necessary for calibrating the Sentinel II for the lubricant volume required for one cycle of the divider valve assembly. To determine this number: (1) locate the divider valve assembly that has the lube system cycle switch mounted on it; (2) add the output volume numbers stamped in the upper right corner of each of the assembly's valve sections (i.e. the 6 from a 6T or 6S section, the 24 from a 24T or 24S section, etc.); (3) double the sum quantity; and (4) subtract any individual output value(s) that is connected to an output line that is not feeding a lubrication point or another secondary feeder assembly (i.e. a line that is

returning oil to the reservoir, or any other destination that is not a rotating/moving lubrication point).

Pressing and holding in the **SLCT** button advances the value displayed until the button is released (to a maximum of 9999). Pressing and holding in the **RST/CLR** button decreases the value displayed until the button is released.

Note that changing the port total changes the displayed alarm rate. Always reset the alarm rate after altering the port total.

Press the **PRGM** button to advance to the next programming option.

**Fault Setup:** Pressing the **SLCT** button toggles selections between INTERLOCKED, INDEPENDENT, and DISABLED. Choosing INTERLOCKED ties the two zones into a first alarm indication only. If the alarm is INDEPENDENT, then each zone is allowed to register a fault when its rate limit has been exceeded. This allows the Sentinel II to be used to monitor two separate systems. If the alarm is DISABLED, no fault will be generated from that zone. Note: Changing the status of one alarm zone may automatically change the status of the other zone.

Press the **PRGM** button to advance to the next programming option.

**Flow Alarm On:** Pressing the **SLCT** button toggles selections between LOW FLOW, HIGH FLOW and HI & LOW FLOW alarms.

Press the **PRGM** button to advance to the next programming option.

**Low Flow Set:** This option appears if LOW FLOW or HI & LOW FLOW is selected. If HIGH FLOW only was selected, skip to the HIGH FLOW SET section. The low flow rate is programmed similarly to the valve total. The alarm is based on a minimum usage rate per 24 hours. Should the usage drop below that value, the zone will go into fault and display a letter "L" in the zone status line for that zone.

Pressing and holding in the **SLCT** button advances the value displayed until the button is released (to a maximum of 9999).

Pressing and holding in the **RST/CLR** button decreases the value displayed until the button is released.

**NOTE:** You will not be allowed to exceed 85% of the HIGH FLOW value if the HI & LOW FLOW is selected.

Press the **PRGM** button to advance to the next programming option.



**High Flow Set:** This option appears if HIGH FLOW or HI & LOW FLOW is selected. If LOW FLOW only was selected, skip to the ENABLE TACH section. The high flow rate is programmed similarly to the valve total. The alarm is based on a maximum usage rate per 24 hours. Should the usage go above that value, the zone will go into fault and display a letter “H” in the zone status line for that zone.

Pressing and holding in the **SLCT** button advances the valve displayed until the button is released (to a maximum of 9999). Pressing and holding in the **RST/CLR** button decreases the value displayed until the button is released.

**NOTE:** You will not be allowed to drop within 15% of the LOW FLOW value if the HI & LOW FLOW is selected.

Press the **PRGM** button to advance to the next programming option.

**Enable Tach:** Pressing the **SLCT** button toggles between YES and NO. If the tachometer is not to be enabled, no further options will be asked for the zone. Enabling the tachometer will add a + sign to the display screen to indicate that alarm times are being dynamically adjusted. Tachometer parameters selected are programmed common to both zones. Settings made for Zone 1 are automatically entered for Zone 2.

Press the **PRGM** button to advance to the next programming option.

**Set # Pulses/Rev:** The tachometer input is based on digital pulses that it sees. This requires the programming of the number of pulses the sensor will see in one revolution of the pump drive mechanism.

Pressing and holding in the **SLCT** button advances the count to a maximum of 20 pulses per shaft revolution. Pressing and holding in the **RST/CLR** button decreases the value displayed until the button is released.

Press the **PRGM** button to advance to the next programming option.

**Set Normal RPM:** This is the normal speed at which the pump drive mechanism is expected to operate. Pressing and holding in the **SLCT** button advances the rpm to a specified maximum until the button is released (see Table 1 for limits). Pressing and holding the **RST/CLR** button decreases the rpm displayed until the button is released. The minimum selectable speed is 50 rpm.

Pulses/Rev	RPMmax.	Pulses/Rev	RPMmax.
1	5000	11	454
2	2500	12	416
3	1666	13	384
4	1250	14	357
5	1000	15	333
6	833	16	312
7	714	17	294
8	625	18	277
9	555	19	263
10	500	20	250

**Table 1. Maximum RPM for Pulses/Rev.**

The Sentinel II program allows the machine and lubricator pump speed to vary without causing a high or low lube fault. As the actual measured rpm varies from the target normal rpm, the fault rate will also vary by the same deviation percentage. The maximum deviation from the target fault setpoints is +/-50%.

Example:

A drive is expected to operate at 100 rpm. The low flow rate for Zone 1 is set to 30 pints per day. If the drive is reduced to 75 rpm (or 75%), the low flow fault point is adjusted down to 22.5 pints per day (also 75%). Note that the minimum and maximum dynamically adjusted values are +/- 50% (45 pints at 150 rpm and 15 pints at 50 rpm.)

Press the **PRGM** button to advance to the next programming option.

Since there are no further options, the display will return to the start of the CONFIGURATION? ZONE 1 selection. At this point, press the SLCT button to toggle to CONFIGURATION? ZONE 2.

**NOTE:** Pressing **RST/CLR** (clear) at this time exits the programming mode and asks if the changes made should be permanent. Use the **SLCT** button to choose the desired response and press the **PRGM** button to exit the programming field and return back to the monitor mode.

## Configuration? Zone 2

The method of configuring Zone 2 is the same as for Zone 1. If Zone 2 does not need to be configured, press the **SLCT** button to toggle to SERIAL PORT.

### Serial Port

If a serial port connection is not being used, simply press the **SLCT** button to toggle to Global Settings.

With the display showing Serial Port, press the **PRGM** button to enter the options for the serial port.

**Baud Rate:** Pressing the **SLCT** button allows the changing between 1200, 2400, 4800 and 9600 rates.

Press the **PRGM** button to advance to the next programming option.

**Word Length:** This is permanently set to 8 bits.

Press the **PRGM** button to advance to the next programming option.

**Stop Bits:** Pressing the **SLCT** button allows the changing between 1 and 2 bits.

Press the **PRGM** button to advance to the next programming option.

**Parity:** Pressing the **SLCT** button allows the changing between ODD, EVEN and NONE.

Press the **PRGM** button to advance to the next programming option.

Since there are no further options, the display will return to the start of the serial port selection. At this point, press the **SLCT** button to toggle to the Global Settings.

## Global Settings

With the display showing GLOBAL SETTINGS, press the **PRGM** button to enter the options for global settings.

**Faults To Skip (Nuisance Faults):** This option allows the Lube Sentinel II to ignore nuisance faults. It will delay the logging of a fault until one, two, or three consecutive faults are received. These values are changed by pressing the **SLCT** button. The normal operation setting uses 1 (faults on the first occurrence of a time out). If 2 or 3 is selected, a + sign will be displayed in the monitor window to indicate that alarm times are being dynamically adjusted. (Note that the + sign also appears if the tachometer option is chosen.)

Press the **PRGM** button to advance to the next programming option.

**Invert Relays (Fault Relay Logic):** This option allows the selection of whether the zone fault relays and the TTL output will energize or deenergize when a fault is registered. Pressing the **SLCT** button toggles the selection between YES and NO. With this option set to NO, the fault relay contacts will be deenergized during normal system operation and energize upon a fault. With this option set to YES, the fault relay contacts will be energized during normal system operation and deenergize upon a fault.

Press the **PRGM** button to advance to the next programming option.

Since there are no further options, the display will return to the start of the global settings selection. At this point, pressing the **SLCT** button returns to the Configuration? Zone 1 option.

To review or change any of the settings, repeat the above steps.

## Exit/Save Changes

Pressing the **RST/CLR** button at any time moves to the exit routine. You will be prompted to save any changes made. The default response is NO. If all the modifications to the Sentinel II are satisfactory and ready to become permanent, press the **SLCT** button to change the response to YES, then press the **PRGM** button. All changes will be made and the Sentinel II returns to the monitor mode. Pressing any other button, or leaving the response set to SAVE CHANGES NO, causes the indicated changes to be erased, and the Sentinel II will again be returned to monitor mode. Note that once the configuration data has been saved, pressing the **RST/CLR** button will not undo the new values.

### CIRCUIT BOARD CONNECTIONS

All electrical connections are made to terminals along both sides and the bottom of the main circuit board, except for serial communications. Serial communication connections are made via a special plug-in header block. See Figure 2.

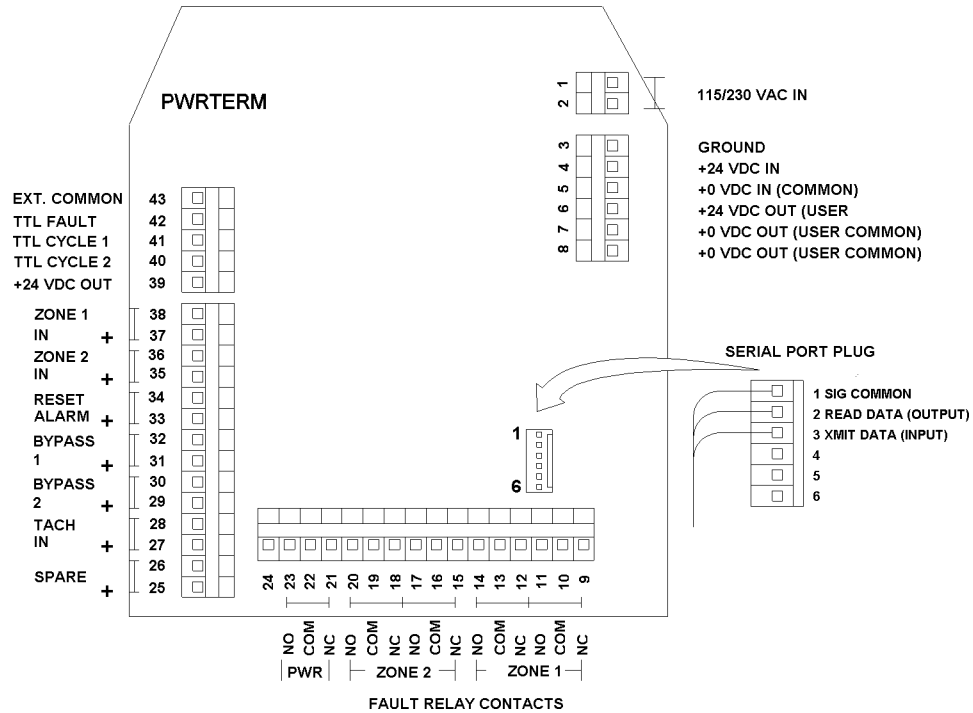

Figure 2. External Connection Terminals

### Terminal Strip Right Side - Power Connections (See Figure 3.)

- Terminals 1 & 2: 115/230 VAC power input terminals (polarity insensitive)
- Terminal 3: Earth Ground
- Terminal 4: + 24 VDC Input
- Terminal 5: 0 VDC Input
- Terminal 6: + 24 VDC Out ( for sensor use )
- Terminal 7: 0 VDC Out ( for sensor use )
- Terminal 8: 0 VDC Out ( for sensor use )

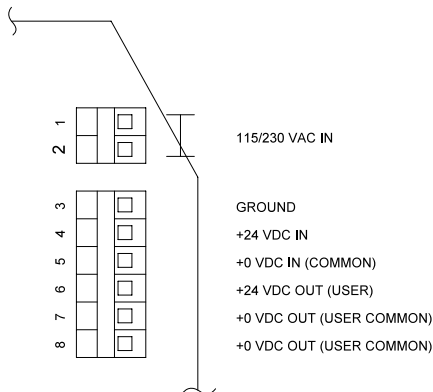
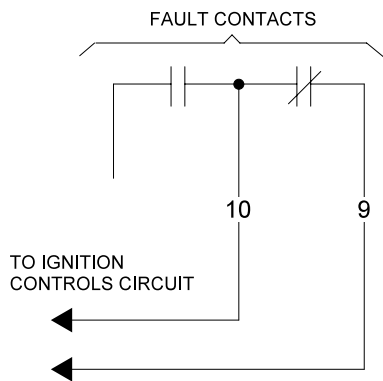

Figure 3. Power Connections

**Terminal Strip Bottom - Fault Relay Connections**

**Terminals 9 thru 14, Zone 1 Fault Relay:** (See Figures 4 through 7.) The zone fault relay is a double-pole, double-throw (DPDT) Form-C relay. Relay contacts are wired directly to the terminal strip. Pole "A" uses terminals 9 (N.C.), 10 (com) and 11 (N.O.). Pole "B" uses terminals 12 (N.C.), 13 (com) and 14 (N.O.). There is no power supplied to these contacts. Contacts are rated 0.5 ampere at 125 VAC and 1.0 ampere at 30 VDC. The relays may be programmed to either energize or deenergize during a fault. Figures 4 through 7 provide examples of wiring for Zone 1 faults.



NOTE: DO NOT CONNECT TO HIGH VOLTAGE  
CONNECT TO CONTROLS ONLY.

**Figure 4. Ignition Shutdown**

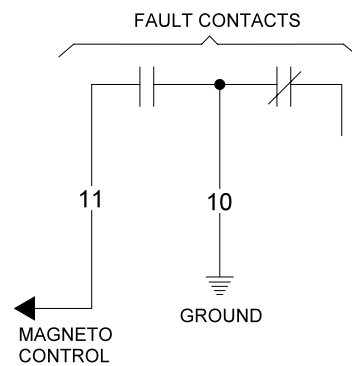

**Figure 5. Magneto Grounding**

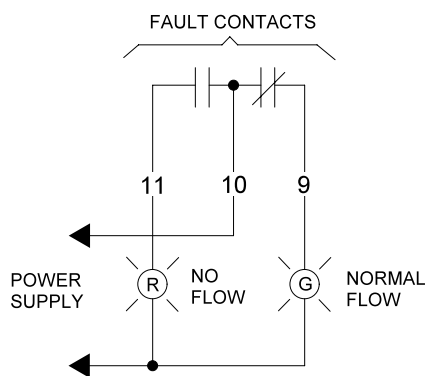

**Figure 6. External Flow-No Flow Lights**

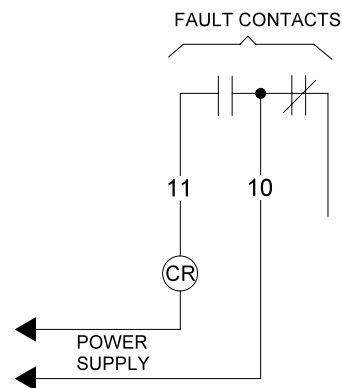

**Figure 7. To Energize External Load (relay coil, etc.)**



**Terminals 15 thru 20, Zone 2 Fault Relay:** (See Figures 8 through 11.) Relay data for Zone 2 is the same as for Zone 1. Pole "A" (for Zone 2) uses terminals 15 (nc), 16 (com) and 17 (no). Pole "B" (for Zone 2) uses terminals 18 (nc), 19 (com) and 20 (no). Figures 8 through 11 provide examples of wiring when Zones 1 and 2 are used.

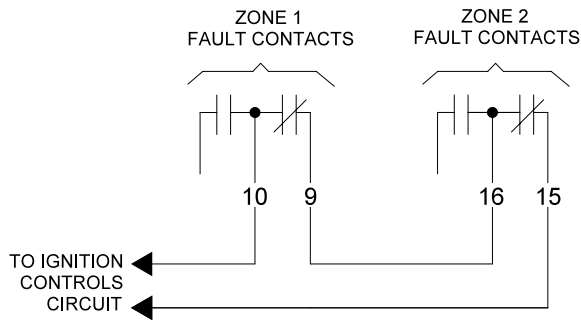

Figure 8. Ignition Shutdown

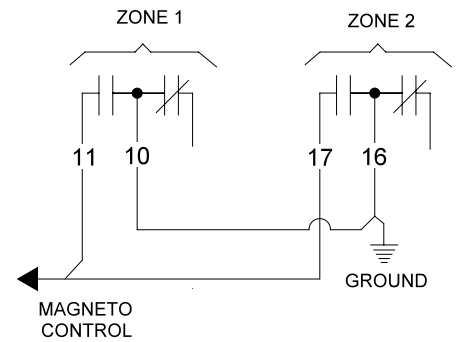

Figure 9. Magneto Grounding

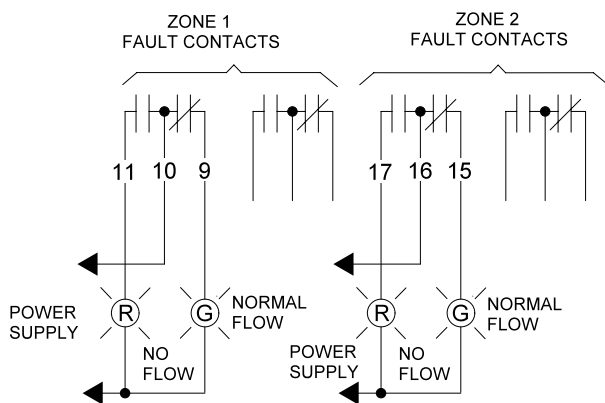

Figure 10. External Flow-No Flow Lights

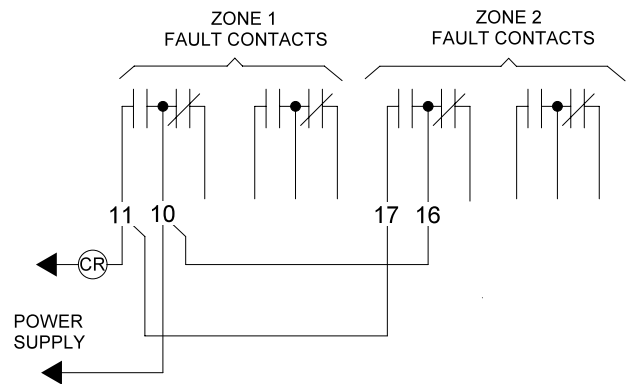
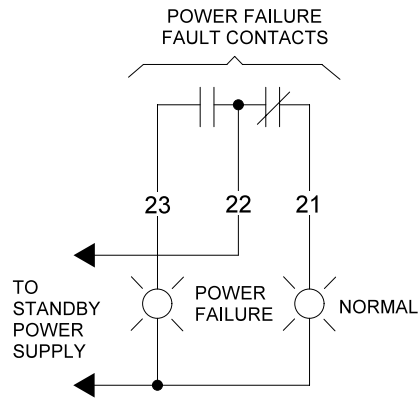

Figure 11. To Energize External Load (relay coil, etc.)

**Terminals 21 thru 23, Power Failure Relay:** (See Figure 12.) The power-fail relay is a single-pole, single-throw (SPST) relay rated for 0.5 ampere at 125 VAC or 1.0 ampere at 30 VDC. Terminals are to Form "C" contacts: 21 (nc), 22 (com) and 23 (no). This relay will be energized as long as power supply voltage is active.



**Figure 12. Power Failure Relay Connections**

**Terminal Strip Left Side Bottom - Sensor inputs (See Figure 13.)**

- Terminals +25 & -26: For Factory Use
- Terminals +27 & -28: Tachometer Input
- Terminals +29 & -30: Bypass Zone 2
- Terminals +31 & -32: Bypass Zone 1
- Terminals +33 & -34: Reset Alarm
- Terminals +35 & -36: Sensor Zone 2
- Terminals +37 & -38: Sensor Zone 1

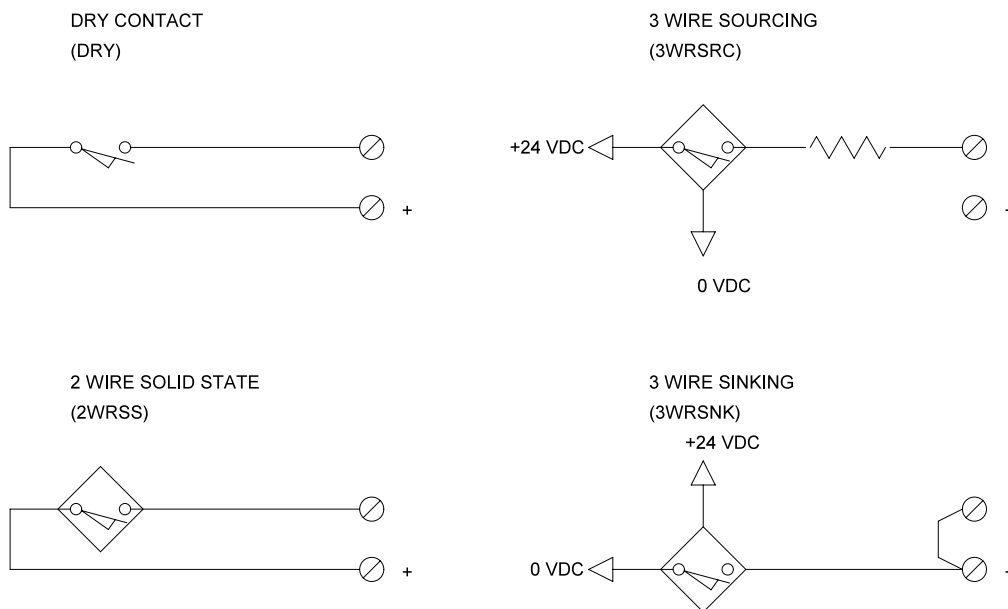
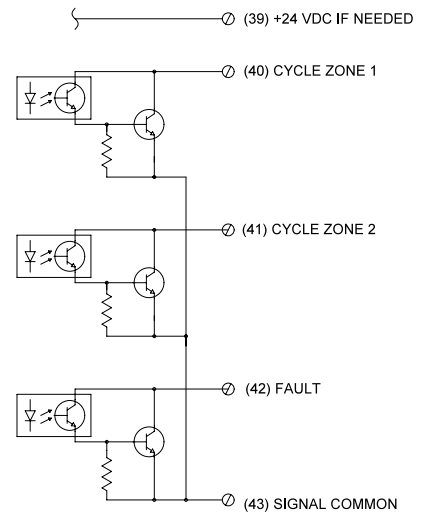

**Figure 13. Typical Input Devices**

**Terminal Strip Left Side Top - Open Collector Outputs (See Figure 14.)**

- Terminal 39: + 24 VDC Out
- Terminal 40: Sensor Echo Zone 1
- Terminal 41: Sensor Echo Zone 2
- Terminal 42: System Fault
- Terminal 43: Floating Drive Common

**CAUTION:** These outputs are open collector, floating TTL outputs. There are no protection devices on these drivers. If the transistor output is connected directly to +24 volts with no load, these devices may be damaged. These drivers are optically isolated from the local power supply and their commons are floating. To utilize these drivers, Terminal 43 must be connected to the common of the voltage supply for the device being driven (such as a PLC input power supply, input common).



**Figure 14. TTL Output**

**SAFETY SET**

The “Safety Set” is a plug-in option available for the Sentinel II. It allows the operator the ability to manually activate the function buttons from outside of the enclosure. This is desirable when the Sentinel II is used in a hazardous environment, as the enclosure need not be opened for routine interrogation or to reset faults. Power must be removed prior to installing the “Safety Set” module into the face of the Sentinel II. Care should be exercised to ensure that the module is properly aligned and all pins are in their proper sockets. The function buttons are activated by placing the magnetic Datawand over the “Safety Set” target above the desired button. The Datawand activates the sensor through the window and keeps it activated until the Datawand is removed. Caution should be used in handling and storing the Datawand as it emits a strong magnetic field. Bringing the Datawand near magnetic media found in credit cards, floppy diskettes, or audio tape, may cause information to be destroyed.

**SERIAL COMMUNICATIONS**

It is possible to communicate with the Sentinel II from up to 100 feet via an RS-232 type port. Information may be read from or written to the Sentinel II by a personal computer (or other intelligent device). Communication is a master/slave protocol with the Sentinel II as the slave and the PC as the master. With the exception of a sign-on message when powered up, the slave will not send any data or information unless requested by the master. All data is sent across the serial port as ASCII characters with leading zeros suppressed. A **BYTE** can be up to three characters and an **INTEGER** up to five characters. Each command and each response is terminated with a carriage return (CR) (ASCII - Hexadecimal 0D or Decimal 13). If the data is not presented in the correct format, the command is not executed. Note that a “read” should be made after doing a “write” to verify that the proper action has taken place.

**NOTE:** Changes made through the serial link are active but are not permanent until the “save to E<sup>2</sup>” command (WC) is issued. If the WC command is not issued, turning the power off and on restores the originally saved operating parameters.

**Data Definitions:**

1. **R1z** Read settings of Zone 1 or 2. The z is set to either 1 or 2. The returned message is a data structure arranged in the following order:
  - a. **BYTE** - 0 or 1 indicates whether the zone is enabled.
  - b. **BYTE** - Unit of measurement on the display.
    - 0 = Ounces
    - 1 = Pints
    - 2 = Gallons
    - 3 = Liters
    - 4 = Milliliters
    - 5 = Counts
  - c. **BYTE** - Interlock of alarms.
    - 0 = Alarm Disabled.
    - 1 = Alarm Zones Interlocked (First alarm).
    - 2 = Alarms Independent.
  - d. **BYTE** - Alarm Generation.
    - 0 = Low Flow Alarm Only.
    - 1 = High Flow Alarm Only.
    - 2 = Both Low and High Flow Alarms.
  - e. **BYTE** - 0 or 1 indicates whether the Tachometer is enabled.
  - f. **INTEGER** - Block total.
  - g. **INTEGER** - Low flow limit for alarm.
  - h. **INTEGER** - High flow Limit for alarm.
  - i. **INTEGER** - Tachometer setting for normal RPM.
  - j. **BYTE** - Tach pulses per RPM.
2. **R2z** Read the current status of Zone 1 or 2. The z is set to either 1 or 2. The returned message is a data structure arranged in the following order:
  - a. **BYTE** - Cycle Position. Indicates if the input is opened or closed (0 or 1).
  - b. **INTEGER** - Cycle Timer. Running time in 0.1 seconds since start of cycle.
  - c. **INTEGER** - Last Cycle Time. Time of the last cycle.
  - d. **INTEGER** - Cycle Count. Number of cycles since last reset.
  - e. **BYTE** - Fault Status (N/F) for Normal or Fault.
3. **R3**  
**INTEGER** - Read current RPM.
4. **R4**  
**BYTE** - Read the number of faults skipped before signaling a fault (value= 1, 2 or 3).
5. **R5**  
**BYTE** - Read if relay output is inverted.
  - 0 = Normal
  - 1 = Inverted
6. **W1zx** Set Zone Enable/Disable.
  - a. **BYTE** z = 1 or 2 for the zone being addressed.
  - b. **BYTE** x = 0 or 1 to disable or enable the zone.
7. **W2zx** Set zone unit of measure.
  - a. **BYTE** z = 1 or 2 for the zone being addressed.
  - b. **BYTE** x = selects the units to display.
    - 0 = Ounces
    - 1 = Pints
    - 2 = Gallons
    - 3 = Liters
    - 4 = Milliliters
    - 5 = Counts
8. **W3zx** Set zone interlock.
  - a. **BYTE** z = 1 or 2 for the zone being addressed.
  - b. **BYTE** x = Interlock of alarms.
    - 0 = Alarm Disabled.
    - 1 = Alarm Zones Interlocked (First alarm).
    - 2 = Alarms Independent.
9. **W4zx** Set high/low alarm limits.
  - a. **BYTE** z = 1 or 2 for the zone being addressed.
  - b. **BYTE** x = Alarm Generation.
    - 0 = Low Flow Alarm Only.
    - 1 = High Flow Alarm Only.
    - 2 = Both Low and High Flow Alarms.
10. **W5x**  
**BYTE** - Turns the tachometer on or off.
  - 0 = Disabled
  - 1 = Enabled
11. **W6zxxxx** Set the port total.
  - a. **BYTE** z = 1 or 2 for the zone being addressed.
  - b. **INTEGER** xxxx = 5 to 9999 (thousandths of a cu-in).
12. **W7zxxxx** Set Low Flow Alarm.
  - a. **BYTE** z = 1 or 2 for the zone being addressed.
  - b. **INTEGER** xxxxx = 5 to 65535 per sentinel specifications. Low Flow Alarm should be at least 10% less than the High Flow Alarm.
13. **W8zxxxx** Set High Flow Alarm.
  - a. **BYTE** z = 1 or 2 for the zone being addressed.

- b. **INTEGER** xxxxx = 0 to 65535 per sentinel specifications. High Flow Alarm should be at least 10% greater than the Low Flow Alarm.
- 14. **W9xxxx** Set normal tachometer speed.  
**INTEGER** xxxx = 50 to 5001.
- 15. **Waxx** Set tachometer pulses per revolution.  
**INTEGER** xx = 1 to 32.
- 16. **WB** Reset Faults.
- 17. **WC** Save Data to EEPROM. Programming changes become permanent.
- 18. **WDx** Set the fault count to alarm on, where x is 1, 2 or 3.
- 19. **WEx** Set the polarity of the fault relays.
  - a. 0 = No. Relays not inverted, normally deenergized, energize on a fault.
  - b. 1 = Yes, Relays are inverted, normally energized, deenergize on a fault.

**Serial Communication Header**

The serial communications are wired through a 6-point header on 0.1 inch centers (see Figure 15). Only three pins (1 thru 3) are used. The other end of this cable may be connected to a personal computer. Pin 1 (nearest to transformer) is the signal ground. Pin 2 is an output that connects to received data at PC. Pin 3 is an input that connects to the transmit data of the PC. (Refer to Table 2.)

Sentinel Header Pin #	Description	PC DB-9F	PC DB-25F
1	Signal Ground	5	7
2	Read Data	2	3
3	Send Data	3	2

**Table 2. Serial Pin Data**

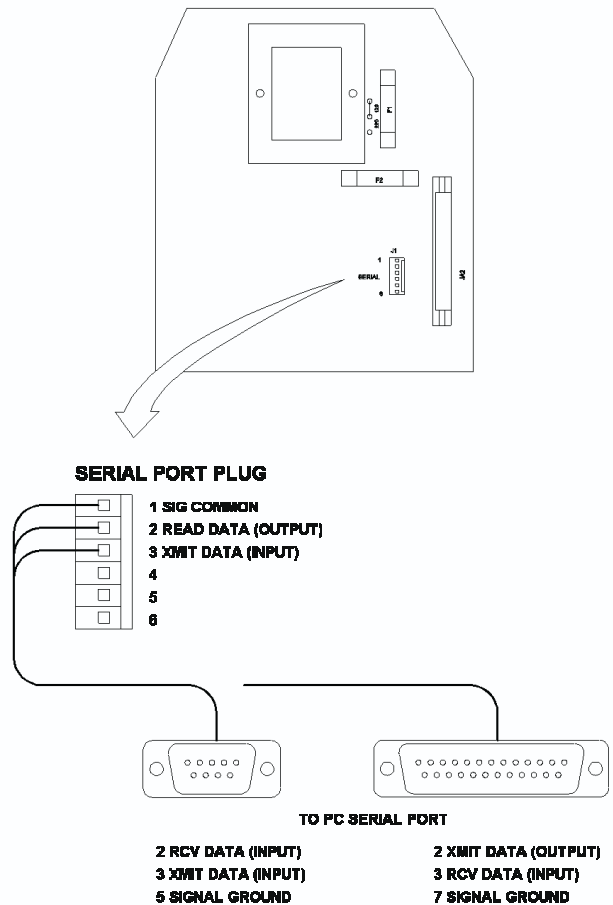

**Figure 15. Serial Port Wiring**



### WIRING PRACTICES

Wiring for Sentinel II should be done with care, and with full awareness of the environment in which the device is installed. Electrical interference from improperly installed equipment may cause erratic behavior of the device.

Be sure that the device is connected to an “earth ground.” This allows the filter circuits to function properly. Ground connections should NOT be connected to conduits or other electrical boxes. The ground wire should be connected to a grounding rod, or a grounded bus bar that is tied to a grounding rod in the earth.

When installing the Sentinel II, 18 to 24 gauge machine tool wire (type MTW) may be used. 18 gauge wire is recommended for the input power. All wiring should be kept as short as possible. There should be no loops to use up extra wire. Wiring should be bundled away from circuits of dissimilar function (i.e., external alarm

circuitry should be bundled away from sensor lines). Wires should be tucked away from the module, toward the sides of the enclosure, with sensor, power and alarm wiring being segregated.

It is recommended that the wiring be run in its own conduit to minimize electrical interference. If the installation is in an area of high electrical noise/interference, or in trays with other control wiring, a shielded cable pair is recommended. Shielded cable should be used on applications where engines or heavy-duty motors are in close proximity to the monitor, wiring or sensors. If shielded cable is used, the shield should stay intact as close to the termination screws as possible. (Do not remove shielding from the cable if it is in a shared tray.) The shield should be clipped at the sensor and connected to the designated ground on the monitor. DO NOT connect the shield wire at BOTH ENDS. Grounding the shield wire at both the monitor and the sensor may create a ground loop and become the source of an electrical anomaly.

### DIMENSIONS (See Figure 16.)

Inches (mm)

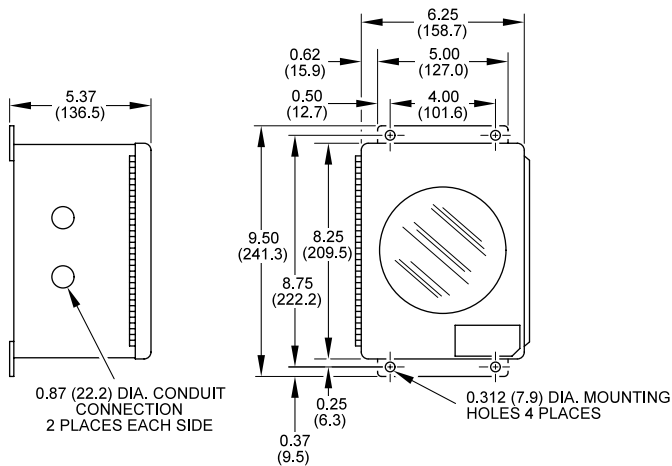

JIC ENCLOSURE

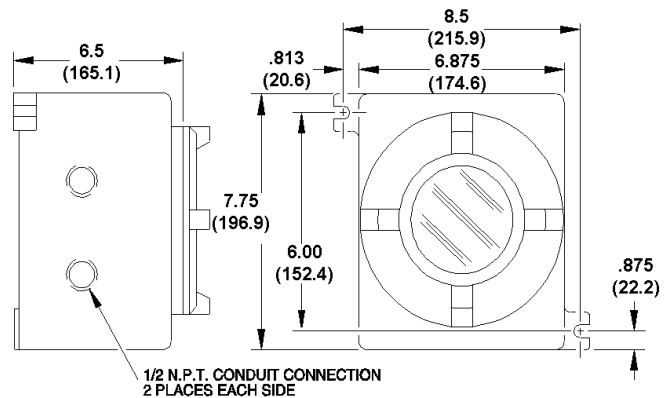

EXPLOSION-PROOF ENCLOSURE

Figure 16. Dimensions

**SPECIFICATIONS**

**Input Power Requirements:**

115 VAC - 100 ma; 230 VAC - 50 ma  
 24-30 VDC - 200 ma

**Fuses FU-1 & FU-2:**

- 1/4" x 1" Size: 0.5 AMP, 250 VAC, Medium Lag (Buss # AGC, or equivalent)
- 5mm x 20 mm Size: 0.5 AMP, 250 VAC, Medium Lag (Buss # GMA-500 or equivalent)
- Uses Medium Lag Fuses Only.
- Do Not Use Fast Acting Fuses.

**Proximity Switch Pulse Inputs:** 24 VDC/12ma each

**Tach Sensor Pulse Input:** 24 VDC/12 ma

**Zone Bypass and Alarm Inputs:** 24 VDC/12 ma each

**Relay Outputs Contact Ratings:**

Rated load 0.5 A at 125 VAC, 1 A at 30 VDC  
 Maximum carry current 2A  
 Maximum operating voltage 250 VAC, 220 VDC  
 Maximum switching capacity 62.5 VA, 60W  
 Minimum permissible load 10 µA 10 mVDC

**Relay Coil Current Consumption:**

70 ma @ 115 VAC; 150 ma @ 24 VDC;  
 40 ma @ 230 VAC

**Communications Port Adapter:**

Waldom-Molex Housing # 22-01-3067  
 Waldom-Molex Pins # 08-50-0114  
 Alternative Parts: AMP Housing # 770602-6  
 AMP Pins #770666-1  
 TTL Outputs (Non Fused) 24 volts DC Max 100 ma Max.

**Maximum Pulse Rate:** 300 Per Minute @ 50% Duty

**Cycle**

**Maximum Cycle Time:** 10.9 Minutes

**Ambient Temperature Range:**

-4 °F to +158 °F (-20 °C to +70 °C)

**Net Weight (Approx.):**

JIC: 8.4 lbs  
 Explosion-Proof: 18.3 lbs

**Figure 17.**

**Explosion-Proof Enclosure (Class 1, Group B/C/D, Division 1: NEMA 4-7)**

A listed Cast Aluminum Explosion-Proof Enclosure with a 3" diameter glass window is offered as a standard option for applications in hazardous environments.



**Figure 19. Board Set**

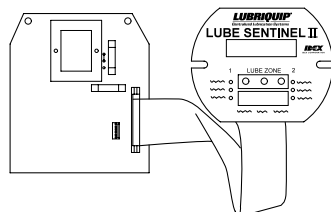

**ORDERING INFORMATION**

**Lube Sentinel II in JIC Enclosure:**

115 VAC ..... 162-300-690  
 230 VAC ..... 162-300-691

**Lube Sentinel II in Explosion-Proof Enclosure**

Class I, Groups B, C and D, Division 1  
 Class II, Groups E, F, and G, Division 1:

115 VAC ..... 162-300-700  
 230 VAC ..... 162-300-701

**Retrofit Packages. Include Lube Sentinel II**

Module and adapter kit for use in:

**Pre-existing JIC Enclosure:**

115 VAC ..... 560-002-720  
 230 VAC ..... 560-002-967

**Pre-existing Class I, Group C and D Enclosure:**

115 VAC ..... 560-002-730  
 230 VAC ..... 560-002-968

**Pre-existing Class I, Group B Enclosure:**

115 VAC ..... 560-002-740  
 230 VAC ..... 560-002-969

**Logic Module with Cord:**

115 VAC ..... 572-144-380  
 230 VAC ..... 572-144-380

**Power Module:**

115 VAC ..... 572-144-390  
 230 VAC ..... 572-144-391

**Safety Set ..... 560-002-011**

**DataWand only ..... 560-002-580**



**Figure 18. JIC Enclosure (NEMA 12)**

An oil-tight, dust-proof JIC sheet metal enclosure with a window on a hinged door is offered as a standard option for general industrial applications.

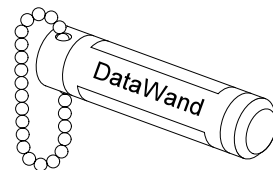

**Figure 20. DataWand**

## PROGRAMMING DATA SHEET FOR LUBE SENTINEL II MONITOR

**NOTE:** Use this sheet (or make copies of this page) as a guide for programming. Use PRGM button to shift to next option and SLCT button to switch to next selection. When you have completed entering program, do not forget to "save" or changes will be deleted. (Use RST/CLR to reset or clear changes.)

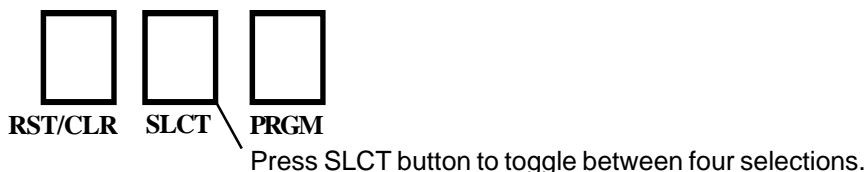
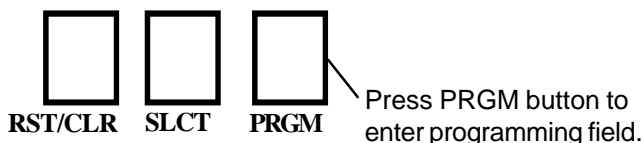

### Selections

CONFIGURATION? ZONE 1	CONFIGURATION? ZONE 2	SERIAL PORT	GLOBAL SETTINGS
- ENABLE ZONE ____	- ENABLE ZONE ____	- BAUD RATE ____	- FAULTS TO SKIP ____ (Nuisance Faults)
- UNITS OF MEASURE ____	- UNITS OF MEASURE ____	- WORD LENGTH ____	- INVERT RELAYS ____ (Fault Relay Logic)
- PORT TOTAL ____	- PORT TOTAL ____	- STOP BITS ____	
- FAULT SETUP ____	- FAULT SETUP ____	- PARITY ____	
- FLOW ALARM ON ____	- FLOW ALARM ON ____		
- LOW FLOW SET ____	- LOW FLOW SET ____		
- HIGH FLOW SET ____	- HIGH FLOW SET ____		
- ENABLE TACH ____	- ENABLE TACH ____		
- SET # PULSES/REV ____	- SET # PULSES/REV ____		
- SET NORMAL RPM ____	- SET NORMAL RPM ____		

### Options

Once in CONFIGURATION?  
(Zone 1 OR 2), SERIAL PORT,  
or GLOBAL SETTINGS:

