

DESCRIPTION

Trabon Performance Indicators are pressure-sensitive devices that pinpoint excessive pressure in Trabon series progressive lubricating systems. These devices, which are installed in the alternate outlet ports of divider valves, signal a fault either by causing an indicator pin to protrude or by releasing lubricant to the atmosphere.

All Performance Indicators respond quickly to protect the lube system and locate lube line blockage. Two of these devices—the Reset Indicator with Memory and the Rupture Indicator—will stop lube system operation when a fault occurs. If, however, lube system operation must continue in spite of a single line being blocked, the Automatic Relief Indicator should be used. Rupture-to-Atmosphere Indicators for Trabon pumps are also included.

It is recommended that some type of Performance Indicator be used to monitor every working outlet of a Trabon Centralized Lubrication System.

Reset Indicator with Memory

Reset Indicators stop lube system operation when a fault occurs. These devices can be used in either master or secondary divider valves. When a lube line becomes blocked, the resultant high pressure moves pistons (A) and (B) (see Figure 1). This movement compresses the spring and pushes indicator pin (C) through the opening in the cap. The high pressure prevents the affected divider valve piston from completing its cycle, causing a pressure backup through the divider valve which trips a pressure switch upstream from the valve and shuts off the pump. As high pressure is relieved, the spring expands, resetting the pistons. Indicator pin (C) is held in place by o-ring (D) until it is reset manually. This helps locate the lube line that is blocked.

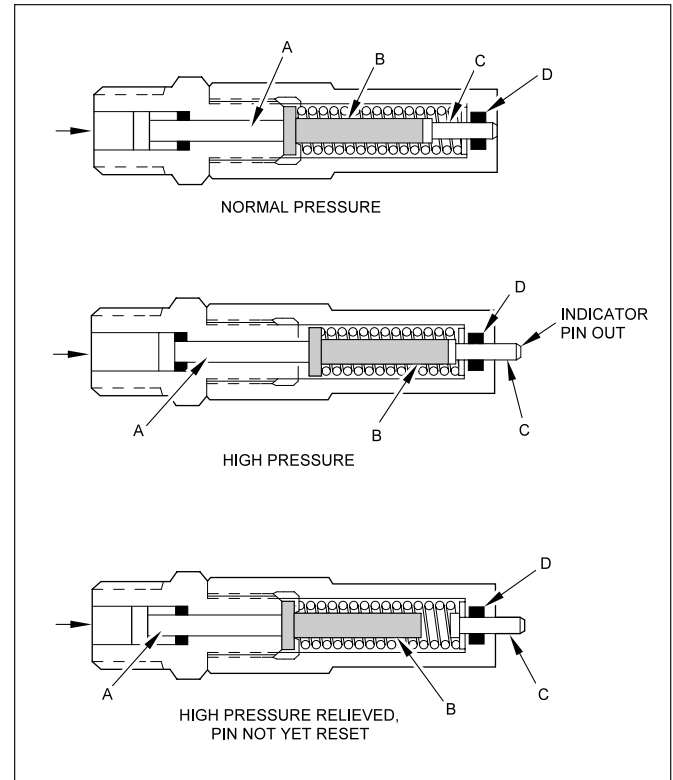

Figure 1. Reset Indicator Operation

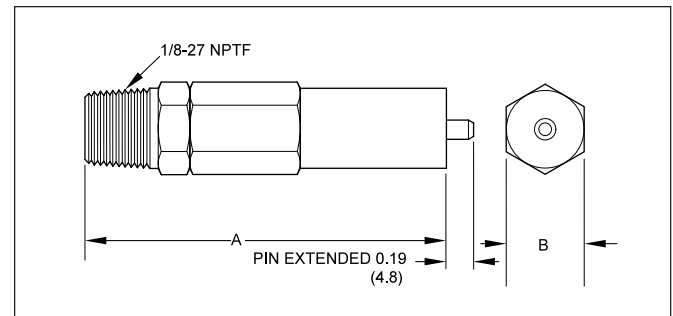

Figure 2. Reset Indicator Dimensions

Pressure (PSI)	1/8" NPTF	1/8" NPSF w/O-Ring	Nickel Plated 1/8" NPTF	1/4" NPTF	7/8"-14 SAE w/O-Ring
	MJ, MH, MS, MXP	MH, MS, MXP	MJ, MH, MS, MXP	MX only	MGO
250	509-931-010	509-932-590	509-932-210	509-932-010	509-932-018
500	509-931-020	509-932-600	509-932-220	509-932-020	509-932-028
750	509-931-030	509-932-610	509-932-230	509-932-030	509-932-038
1000	509-931-040	509-932-620	509-932-240	509-932-040	509-932-048
1500	509-931-050	509-932-630	509-932-250	509-932-050	509-932-058
2000	509-931-060	509-932-640	509-932-260	509-932-060	509-932-068
2500	509-931-070	509-932-650	509-932-270	509-932-070	509-932-078
Dimensions (See Figure 2)					
A	2.34 (59.5)	2.44 (62.0)	2.34 (59.5)	2.47 (62.7)	2.63 (66.8)
B	0.50 (12.7)	0.56 (14.3)	0.50 (12.7)	0.56 (14.3)	1.00 (25.4)
O-Ring	NO	YES	NO	NO	YES

Table 1. Reset Indicator with Memory Ordering Data/Dimensions

Automatic Relief Indicator

These Performance Indicators pinpoint lube line blockage but allow the lube system to continue to supply lubrication to points that are not blocked. They are used primarily in secondary divider valves. The excessive pressure created by line blockage moves a piston, enabling the lubricant to escape through a vent. (See Figure 3.) When the pressure is relieved, the spring resets the piston. Because these devices permit the lube system to keep operating when a lube point is blocked, a separate pressure switch connected to an audible or visual alarm should be used to warn of high pressure.

Pressure (PSI)	1/8" NPTF MJ, MH, MS, MXP	1/8" NPSF w/O-Ring MH, MS, MXP	1/4" NPTF MX only
750 ±20%	508-310-075	508-310-415	508-210-075
1000 ±20%	508-310-100	508-310-425	508-210-100
1250 ±20%	508-310-125	508-310-435	Not Available
1500 ±20%	508-310-150	508-310-445	508-210-150
2000 ±20%	508-310-200	508-310-455	508-210-200
2500 ±20%	508-310-250	508-310-465	508-210-250
3000 ±24%	508-310-300	508-310-475	508-210-300

Table 2. Automatic Relief Indicators

Automatic Relief Indicators used to be identified by the color of the spring retainer in the end of the indicator. Pressure ratings are now stamped on the body of the indicator. Table 3 is shown for reference and to aid in the selection of replacement indicators.

Retainer Color	Pressure Rating
Blue	750
Green	1000
Yellow	1400
Red	1800
Orange	2200
Aluminum	2500
Purple	Consult the Factory

Table 3. Reference Table

Note: If you are replacing indicators that have a pressure rating that is no longer available, it is recommended that you select available indicators with the next higher pressure rating.

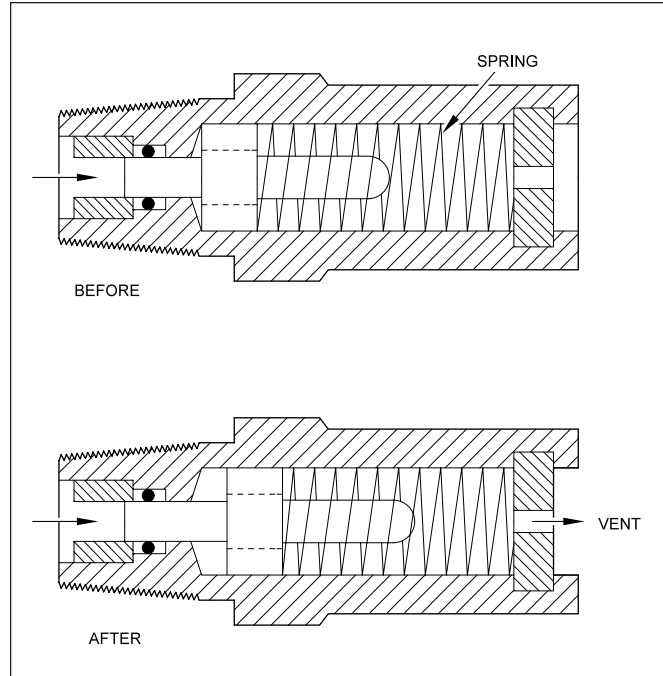

Figure 3. Automatic Relief Indicator Operation

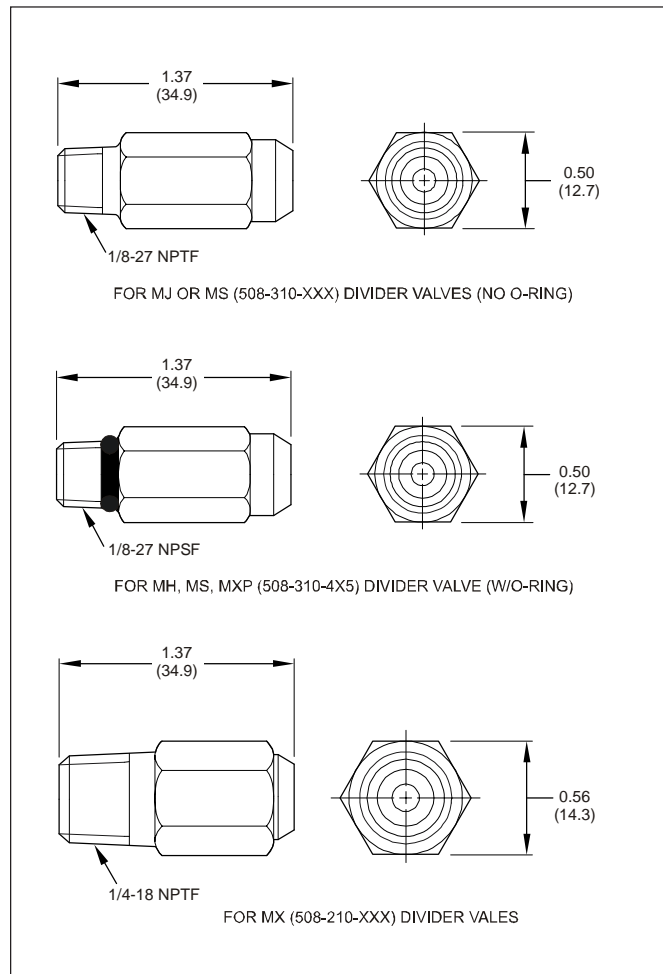

Figure 4. Automatic Relief Indicator Dimensions

Rupture Indicator

Rupture indicators are used on MH divider valve applications where lube system pressures exceed 2,500 psi. The high pressure from lube line blockage causes a disc to rupture. The lubricant then forces an indicator pin to protrude, locating the blockage. (See Figure 5.) The high

pressure backs up through the system and trips a switch to shut the system off. When the fault is corrected, the disc must be replaced and the pin reset manually. See Table 4 for ordering data and Figure 6 for dimensions.

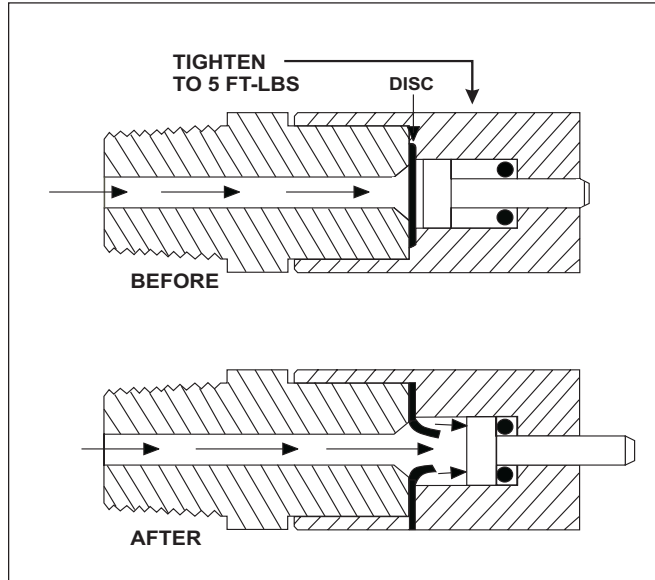

Figure 5. Rupture Indicator Operation

PSI	Complete Assembly		Replacement Disc (3/8" Dia.)	Disc Color
	1/8-27 NPTF	1/8-27 NPSF with o-ring		
2800 ±20%	509-499-620	509-499-625	509-277-000	Green
3700 ±20%	509-499-100	509-499-105	509-278-000	Yellow
4600 ±20%	509-499-120	509-499-125	509-279-000	Red
5500 ±20%	509-499-140	509-499-145	509-280-000	Orange
6400 ±20%	509-499-160	509-499-165	509-282-000	Pink
7300 ±20%	509-499-200	509-499-205	509-283-000	Blue
8200 ±20%	509-499-220	N/A	509-284-000	Purple

Table 4. Rupture Indicator Ordering Data

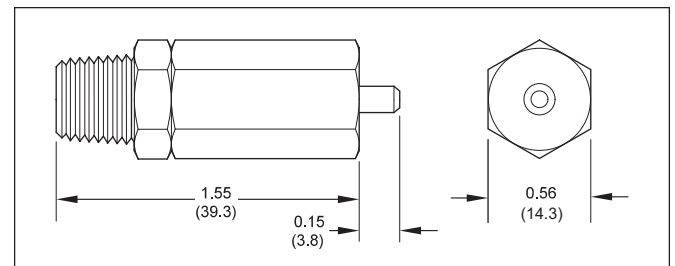

Figure 6. Rupture Indicator Dimensions

Rupture-to-Atmosphere Indicator

These indicators, which are standard on all Lubriquip pumps, provide pump protection and give visual indication of excessive system pressure. The pressure disc ruptures at a predetermined pressure setting, venting lubricant to the atmosphere and relieving the high pressure. (See Figure 7.) See Table 5 for ordering data.

PSI*	Complete Assembly	Replacement	Disc Color	Blowout Disc
For 1/4" NPTF Fittings				
		11/16" Dia.		(Qty = 6)
900	509-206-060	509-290-000	Black	560-900-250
1450	509-206-100	509-292-000	Yellow	560-900-270
1750	509-206-120	509-293-000	Red	560-900-280
2050	509-206-140	509-294-000	Orange	560-900-290
2350	509-206-160	509-295-000	Aluminum	560-900-300
2650	509-206-180	509-296-000	Pink	560-900-310
2950	509-206-200	509-297-000	Blue	560-900-320
3250	509-206-220	509-298-000	Purple	560-900-330
For 1/8" NPTF Fittings				
		3/8" Dia.		(Qty = 25)
900	509-230-060	509-276-000	Black	560-900-050
1450	509-230-100	509-278-000	Yellow	560-900-070
1750	509-230-120	509-279-000	Red	560-900-080
2050	509-230-140	509-280-000	Orange	560-900-090
2350	509-230-160	509-281-000	Aluminum	560-900-100
2650	509-230-180	509-282-000	Pink	560-900-110
2950	509-230-200	509-283-000	Blue	560-900-120
3250	509-230-220	509-284-000	Purple	560-900-130
5000	509-230-350	509-285-200	Brown	560-900-140
For Hi Press 1/8" NPTF Fittings				
		3/8" Dia.		(Qty = 25)
3700	509-494-100	509-278-000	Yellow	560-900-070
4600	509-494-120	509-279-000	Red	560-900-080
5500	509-494-140	509-280-000	Orange	560-900-090
6400	509-494-160	509-282-000	Pink	560-900-110
7300	509-494-200	509-283-000	Blue	560-900-120
8200	509-494-220	509-284-000	Purple	560-900-130
9500	509-230-500	509-285-000	Gray	N/A

* Discs up to 2350 psi have a tolerance of ±500 psi. Discs greater than 2350 psi have a tolerance of ±20%.

Table 5. Rupture-to-Atmosphere Ordering Data

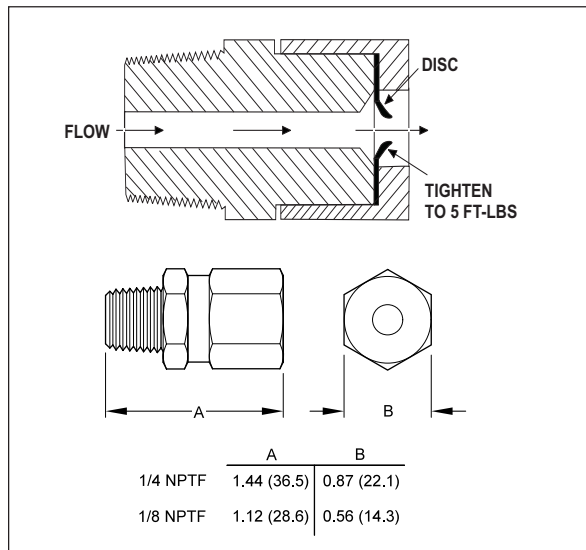

Figure 7. Rupture-to-Atmosphere Operation/Dimensions

Rupture-to-Atmosphere Indicator with Spud Assembly

A spud assembly (see Figure 8) is available to return vented lubricant to the reservoir by way of a tube. See Table 6 for ordering data. A high pressure switch is recommended to provide an audible or visual warning alarm that high system pressure has occurred.

PSI*	Complete Assembly	Replacement Disc (11/16" Dia.)	Color
1450	509-220-101	509-292-000	Yellow
1750	509-220-121	509-293-000	Red
2350	509-220-161	509-295-000	Aluminum

* All pressures have a tolerance of ±500 psi.

Table 6. Rupture-to-Atmosphere w/Spud Ordering Data

Rupture Discs (11/16" Dia.)

The following discs (Table 7) are available (shipped loose) or in packaged quantity. They can be used in either type of Rupture-to-Atmosphere Indicator (509-206-xxx or 509-220-xxx).

PSI*	Disc Part No.	Color	Qty=6
900	509-290-000	Black	560-900-250
1175	509-291-000	Green	N/A
1450	509-292-000	Yellow	560-900-270
1450	509-293-000	Red	560-900-280
2050	509-294-000	Orange	560-900-290
2350	509-295-000	Aluminum	560-900-300
2650	509-296-000	Pink	560-900-310
2950	509-297-000	Blue	560-900-320
3250	509-298-000	Purple	560-900-330

* Discs up to 2350 psi have a tolerance of ±500 psi. Discs greater than 2350 psi have a tolerance of ±20%.

Table 7. Rupture Discs

Fred C. Gilbert Co.
 106 Norris Road
 Bakersfield, Ca. 93308
 661-399-9569
 www.fcgilbert.com

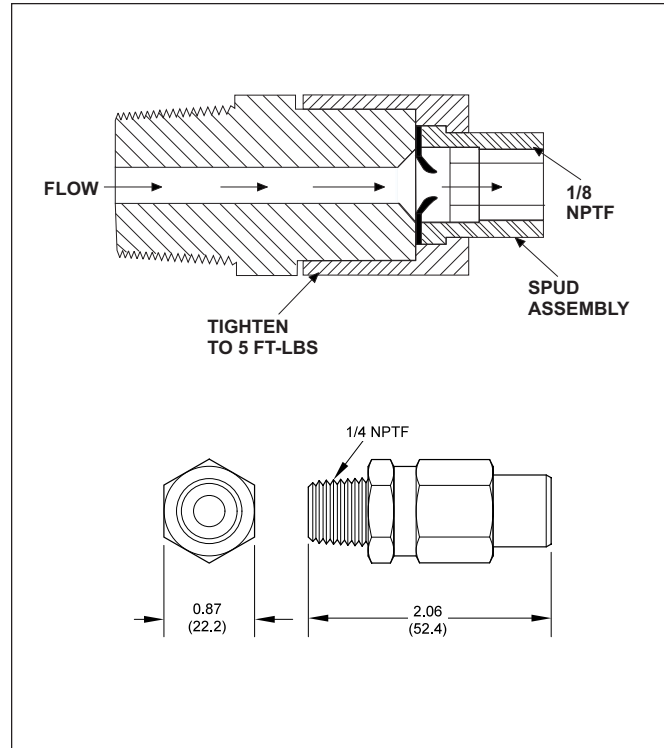

Figure 8. Rupture-to-Atmosphere w/Spud Assembly

Look to LUBRIQUIP, Inc.
 for all of your
 Centralized Lubrication System needs.

Products include:

DIVIDER VALVES: for oil and grease...to 7500 PSI...1 to 20 points from a single valve assembly...up to 400 points from a Master/Secondaries circuit...or systems that handle an entire plant.

PUMPS: fixed and variable displacement...manual and air, hydraulic, electric motor or mechanically driven.

TIMERS/AUTOMATIC CONTROLS: from simple on/off to complete flow and pressure monitoring, either time- or machine-actuated.

ACCESSORY VALVES: balancing, check and flow.

INDICATORS: performance and broken line.

ACCESSORIES: fittings, brackets, clamps, filters and strainers.

TECHNICAL NOTICE

TN-231

Date: February 21, 2005

Subject: Trabon & Manzel Blowout Disc Standardization

Reference: Literature 15401

In line with the Lubriquip initiative to standardize product offerings where duplications exist, we have updated our Blowout Discs. We are in the process of phasing out the 3/8" diameter Half colored Blowout Discs. These parts are a duplicate of the full colored 3/8" Diameter discs. This phase out period may take several months due to current inventory levels.

The upper level assemblies of Rupture-to-Atmosphere Indicators will not be affected by this change. We will continue to offer all 3/8" Blowout Assemblies. To reduce confusion, we have dual rated many of these discs. The below table provides the disc part number, associated low & high pressure blow out assemblies, and their respective pressure ratings. Please keep in mind that the combination of disc and blowout assembly with specific area of contact will produce the pressure relief rating.

For field replacement of the half colored disc in a high pressure rupture to atmosphere assembly, use the corresponding, pressure rated, solid color disc listed in the below table.

Disc	Color	Low Pressure Assembly	Low Pressure Rating (PSI)	High Pressure Assembly	High Pressure Rating (PSI)
509-276-000	Black	509-230-060	900	—	—
509-277-000	Green	509-230-080	1175	509-499-620	2800
509-277-000	Green	—	—	509-499-625	2800
509-278-000	Yellow	509-230-100	1450	509-230-511	3700
509-278-000	Yellow	509-241-100	1450	509-494-100	3700
509-278-000	Yellow	509-499-771	1450	509-499-100	3700
509-278-000	Yellow	—	—	509-499-105	3700
509-279-000	Red	509-230-120	1750	509-494-120	4600
509-279-000	Red	509-241-120	1750	509-499-120	4600
509-279-000	Red	509-499-772	1750	509-499-125	4600
509-280-000	Orange	509-230-140	2050	509-494-140	5500
509-280-000	Orange	509-241-140	2050	509-499-140	5500
509-280-000	Orange	—	—	509-499-145	5500
509-281-000	Aluminum	509-230-160	2350	—	—
509-281-000	Aluminum	509-241-160	2350	—	—
509-282-000	Pink	509-230-180	2650	509-494-160	6400
509-282-000	Pink	509-241-180	2650	509-499-160	6400
509-282-000	Pink	509-499-773	2650	509-499-165	6400
509-283-000	Blue	509-230-200	2950	509-494-200	7300
509-283-000	Blue	509-241-200	2950	509-499-200	7300
509-283-000	Blue	—	—	509-499-205	7300

(Over)

TECHNICAL NOTICE

TN-231

Disc	Color	Low Pressure Assembly	Low Pressure Rating (PSI)	High Pressure Assembly	High Pressure Rating (PSI)
509-284-000	Purple	509-230-220	3250	590-494-220	8200
509-284-000	Purple	509-241-220	3250	509-499-220	8200
509-284-000	Purple	509-499-774	3250	—	—
509-285-200	Brown	509-230-350	5000	—	—
509-285-700	Gray	509-230-500	9500	—	—

Literature 15401 has been updated to reflect this standardization of parts. Literature is available to download at the following web link: <http://www.fcgilbert.com>.

This standardization does not affect the disc tolerances: Discs up to 2350 PSI have a tolerance of ± 500 PSI. Discs greater than 2350 PSI have a tolerance of $\pm 20\%$.

If you should have any questions regarding this notice, please contact a Application Engineer at (800) 494-3733.