

PNEUMATIC LUBE SENTRY VALVE

OPERATION

Initiate lubricant flow from the lube pump serving the divider valve or pump to point system (until flow has been established, the electric or pneumatic circuit to the Lube Sentry must be bypassed). Lubricant passing through the hydraulic section of the valve (See Figure 1 or 2) from port (1) to port (2) moves to piston (3) in the direction of the arrow. The actuator rod (4) is attached to piston (3) and simultaneously moves in the same direction allowing the directional spool (5) in the air valve of the Pneumatic Lube Sentry (See Figure 1) to permit air to flow between port "A" and port "C" or tripping the microswitch(es). (See Figure 2 Note 2 on the Electric Lube Sentry.) The Lube Sentry is now in a flow position.

When lubricant flow stops, spring (6) returns piston (3) in the opposite direction, closing the porting to the lube outlet (7). The lubricant ahead of piston (3) is forced back through the adjustable needle valve (8) at a controlled rate. As piston (3) returns to the right, the attached actuator rod (4) moves the Pneumatic Lube Sentry directional spool (5) permitting air to now flow between port "A" and port "B" (See Figure 1), or changing the position of the microswitch(es) (See Figure 2 Note 2) on the Electric Lube Sentry. The Lube Sentry is now in a no-flow condition. Figure 1 shows a typical no-flow position.

Adjusting needle valve (8) clockwise increases shutdown time. A counterclockwise adjustment decreases the shutdown time.

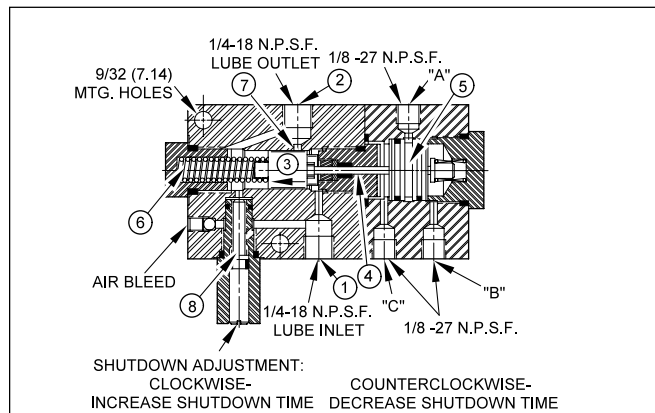

Note 1: Pneumatic Valve Operation (During Lubricant Flow)

Operation	Port "A"	Port "B"	Port "C"
Norm. Open	Air In	Plugged	Air Out
Norm. Closed	Air Out	Air In	Plugged

Figure 1. Pneumatic Lube Sentry Valve



ELECTRIC LUBE SENTRY VALVE

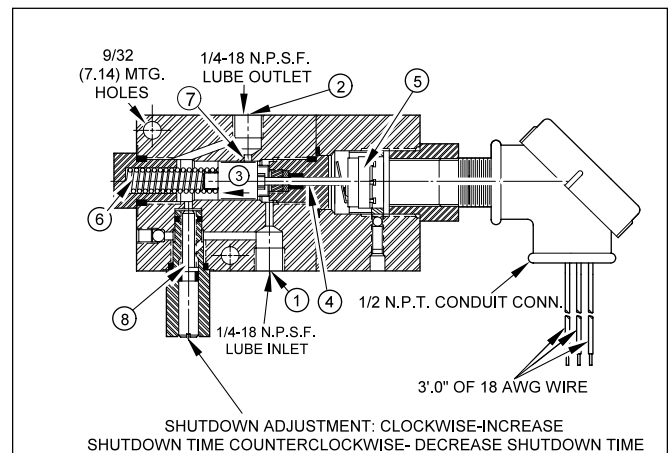

Flow - Green Light - ON; Red Light - OFF

No-Flow - Red Light - ON; Green Light - OFF

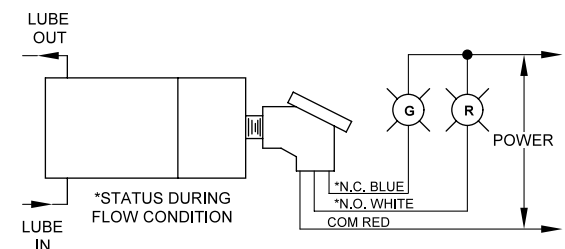

Note 2:

FLOW CONDITION :

For Closed Contact: Use Red and Blue Wires (Red Common)
For Open Contact: Use Red and White Wires (Red Common)

NO-FLOW CONDITION:

For Open Contact: Use Red and Blue Wires (Red Common)
For Closed Contact: Use Red and White Wires (Red Common)

CAUTION: If only two of the three wires are used, tape un-used wire.

Figure 2. Electric Lube Sentry Valve

INSTALLATION

General Lube Line Connection

1. The Lube Sentry Valve should be located in the lube line downstream of pump, filters, and controls, but ahead of the master divider valve. (A high-pressure line filter placed after the pump is insurance against system plugging due to oil-born dirt.)
2. A pressure rupture assembly (Disk Relief Type) must be located in the main lube line between the pump and the line filter.
3. Always install Lube Sentry with "LUBE OUT" port up, to permit natural air purging of the device.

General Shutdown Reaction Adjustment

1. See graphs for minimum flow rates, with various viscosity oils, and shutdown time recommendations.
2. Start with the adjustment screw (Figures 1 & 2, Item 8) flush with end of housing. Turn on lube system with pump discharging oil at normal flow rate and pressure.
3. Slowly rotate adjustment screw clockwise until the electric switch/air valve changes mode (flow condition).
4. Stop oil flow and note time for electric switch/air valve to change mode (no-flow condition).
5. Start normal flow of oil and note that the electric switch/air valve changes mode (flow condition) within two minutes and remains in this mode as long as normal oil flow continues.
6. For positive shutdown indication on the Electric Lube Sentry, an ohmmeter or continuity meter should be connected to wiring as follows: **No flow condition** – continuity between red and white wires. **Flow condition** – continuity between red and blue wires. **Caution** – In an explosive atmosphere, use only approved device for checking continuity
7. This is the minimum shutdown time attainable for the application. The shutdown time can be increased by continuing to turn the adjustment screw clockwise. **Caution** – Do not adjust shutdown time greater than shown on graphs or inconsistent shutdown time will result.

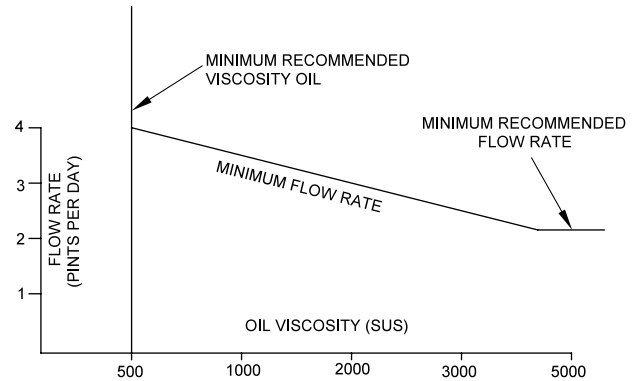

Graph 1. Minimum Flow Rate

NOTE: Do not use below minimum recommended flow rates or inconsistent shutdown times occur.

Pneumatic Lube Sentry Valve Installation

Pneumatic Connections

A. Series Type (in-line) Safety Control Pneumatic Circuits (See Figure 3)

1. Trace pneumatic safety circuits from the source of its take-off air supply through the various safety devices used on the engine and compressor to the entrance of the pilot air port (bonnet port) on the safety control valve or gas shut-off valve.
2. Select the most convenient location to break into the air circuit, either between two other safety devices or between the last safety device and the bonnet port of the safety control valve.
3. Break the air circuit at the selected point and tube the Lube Sentry Valve into the circuit with air flow entering port "A" and leaving port "C" (See Figure 1). If gas is used as the control medium rather than air, tube the exhaust port "B" into a suitable vent line.

CAUTION – Never plug port in series type shutdown circuits.

4. To test device for operation, start engine to initiate flow in the divider valve system. Operation of the air valve within the Lube Sentry will be observed as the tripping out of the reset latch (manual override) lever on the safety control valve (see Figure 3), and the continued operation of the engine. After a short interval of running during which the engine and compressor receive sufficient lubrication and all other safety devices move to the RUN position, dump the output of the pumps serving the divider valve systems by removing the pump blowout disc or a pipe plug from the pump manifold assembly. When the flow to the distribution system stops, the Lube Sentry should operate to dump the pressure in the pneumatic safety circuit, dropping out the safety control valve to stop the engine. (If shutdown action is sluggish, reduce the setting of the adjustable orifice through which air for the safety circuit passes.

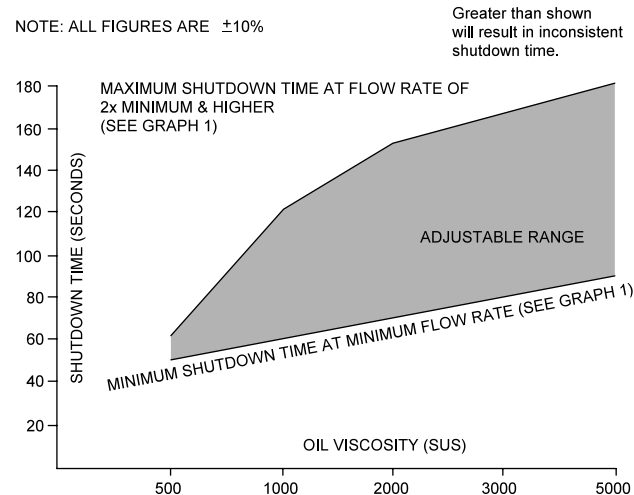

Graph 2. Minimum Shutdown Time

NOTE: At minimum flow rate, the shutdown time is not adjustable. Times indicated are approximate results when the attached procedure is followed. Attempting to increase the shutdown time will result in inconsistent shutdown time.

INSTALLATION (Continued)

The Lube Sentry is provided with a 1/8" air valve. If the control orifice for the safety system is too large, air will be supplied to the Lube Sentry too quickly to permit it to dump properly.)

A pneumatic relay may be operated by the Lube Sentry (see Figure 4).

B. Parallel Type Safety Control Pneumatic Circuits (See Figure 5)

1. Parallel type safety circuits rely on their devices to dump the pilot control pressure on the safety control valve in case of trouble. This control pressure is supplied to the pilot (bonnet) port of the safety shutdown valve through an adjustable orifice which permits enough air to enter the circuit to maintain pressure on the port. When any safety device operates, the pilot pressure is dumped, with the control orifice preventing sufficient air to enter the system to maintain pressure.
2. The Lube Sentry should be teed in to the line serving the pilot port of the safety shutdown valve.
3. Connect port "B" into the safety circuit.
4. Plug port "C".
5. Port "A" (exhaust) may be connected to a vent line if necessary.
6. To test device for operation see item 4 under Series Type.

Electric Lube Sentry Valve Installation

Electric Switch Adjustment and Replacement

The electrical end of the Lube Sentry has been adjusted correctly at the factory. If the electric switch assembly is replaced, repairs required or adjustment necessary, proceed as follows:

Warning: Never remove the Lube Sentry Electric Switch Assembly from the Actuator Assembly or make any adjustments to the Electric Switch without first being sure there is **NO Electricity Present** at the Lube Sentry.

To Replace Electric Switch Assembly

1. After determining there is no electricity to the Lube Sentry, remove the switch assembly from the actuator assembly by removing the four-socket head screws holding the two assemblies together, being careful not to scratch the mating surfaces.
2. Be sure no corrosion or dirt is present. In a no-flow condition, the actuator rod should extend approx. 5/32 inches beyond the actuator rod housing.
3. Replace electric switch assembly. **Caution:** Do not reassemble if scratches, dirt, or corrosion are present on mating surfaces of switch and actuator assembly.

To Adjust Electric Switch Assembly

1. With no lubricant flowing, Lube Sentry should be in shutdown or warning position (switch actuated). You should show continuity between red and white wires, if not, the microswitch is misadjusted or broken.
2. If adjustment is required, remove the electrical connection housing, consisting of conduit elbow and cap, nipple, and adaptor by loosening and removing the adaptor, (Figure 7, Item 31) from the switch housing.
3. Loosen setscrew (Item 26) located on bottom of switch body.
4. Actuating piston must be completely extended (Item 15).
5. Rotate switch enclosure screw (Item 23) clockwise until switch just actuates. (Continuity is obtained between red and white wires.) Rotate additional 1/4 turn after switch actuates.
6. Tighten setscrew (Item 26) to lock nylon ball (Item 25) against switch enclosure screw.
7. If microswitch is defective, replace.
8. Re-adjust switch.

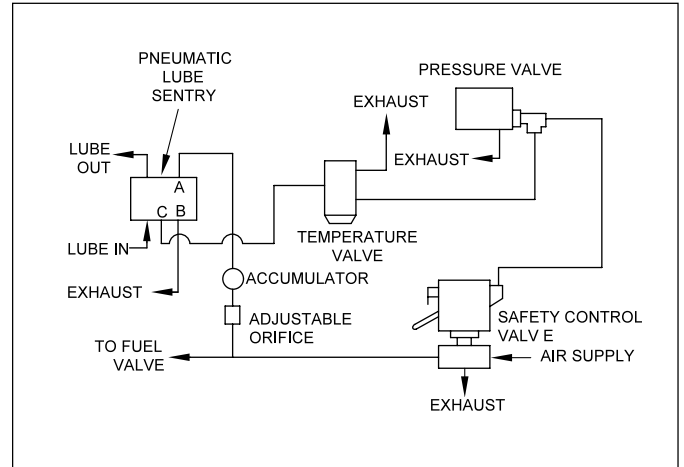

Figure 3. Typical Series Installation of Pneumatic Engine Shutdown Circuit

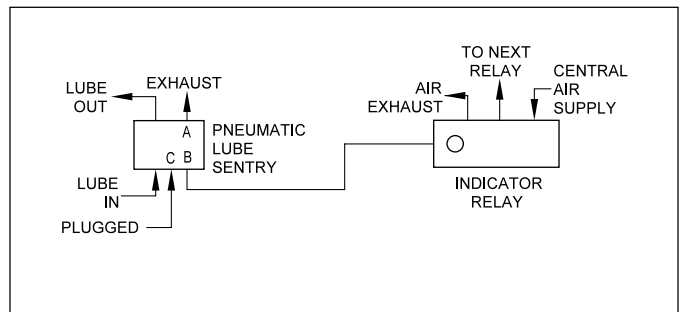
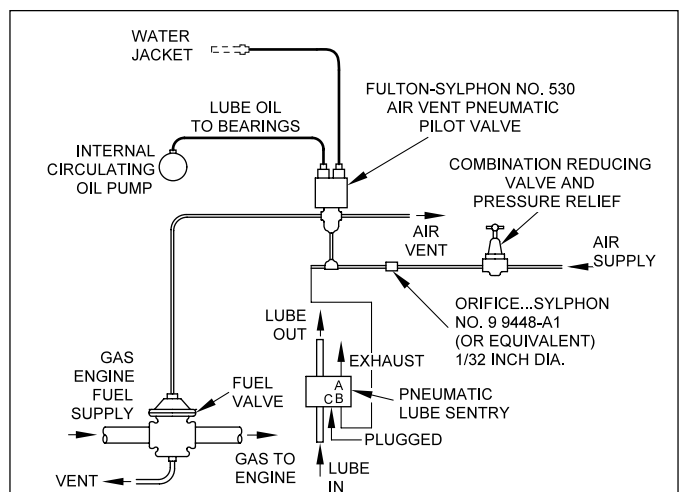

Figure 4. Typical Installation with Pneumatic Indicating Relay



NOTE: Installation of the Lubriquip Pneumatic Lube Sentry as shown on the drawing provides automatic signalling of cylinder lubrication trouble. No flow caused by pump failure, broken line or low oil supply will cause the Lube Sentry to operate, removing air pressure from the fuel valve and stopping the engine.

Figure 5. Typical Parallel Gas Engine Installation of Lubriquip Pneumatic Lube Sentry with Fulton-Sylphon No. 530 Pneumatic Pilot Valve

ORDERING INFORMATION

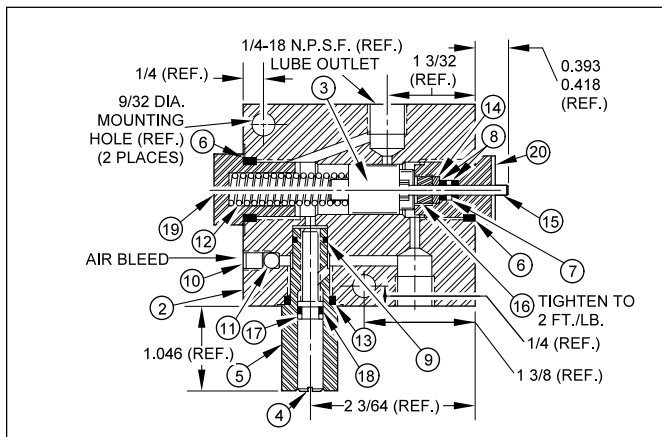

Figure 6. Actuator Assembly

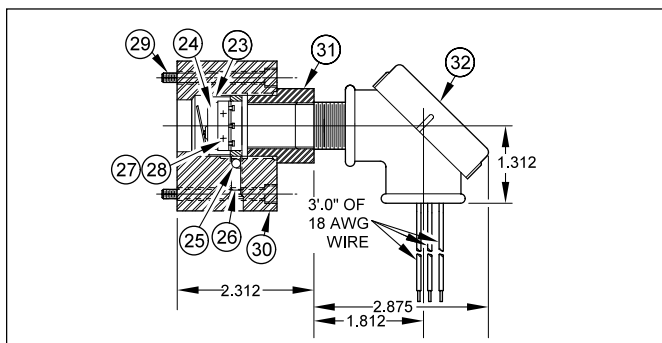

Figure 7. Switch Assembly for Electric Lube Sentry

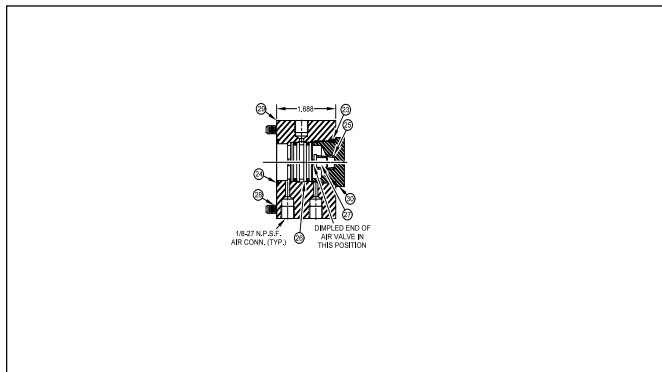

Figure 8. Valve Assembly for Pneumatic Lube Sentry

ITEM	PART NUMBER
Pneumatic Lube Sentry, complete	527-100-190
Pneumatic Valve	527-100-150
Actuator	527-100-130
Electric Lube Sentry, complete	527-100-180
Switch Assembly	527-100-170
Actuator	527-100-130

For more information on the Pneumatic or Electric Lube Sentry Valve consult Literature No. 15831 or your distributor.

ITEM NO.	DESCRIPTION	PART NUMBER	QTY. REQ.
1	Lube Sentry Actuator Assy. (Includes Items 1 thru 20, see Figure 6)	527-100-130	1
2	Body (Matched Fit)	527-100-000	1
3	Piston (Matched Fit)	527-100-010	1
4*	Valve-Adjustment	527-100-062	1
5*	Housing Adj. Screw	527-100-052	1
6*	O-Ring Viton 70 Duro	422-041-140	2
7*	O-Ring Viton 70 Duro	422-040-060	1
8*	Back-up Ring	527-000-760	2
9*	O-Ring	422-040-110	1
10*	Setscrew 1/4-20 x 1/4-1/8 Hex	417-060-020	1
11*	Ball 3/16 Steel	401-030-030	1
12*	Spring-Piston Return	527-100-110	1
13*	O-Ring	422-040-140	1
14*	Spacer O-Ring Retaining	527-100-100	1
15*	Piston-Switch Actuating	527-100-030	1
16*	Locking Screw 3/8-24 x 3/16	416-700-780	1
17*	Back-Up Ring	423-700-038	1
18*	O-Ring	422-040-080	1
19	Screw - Piston Enclosure	527-100-040	1
20	Housing-5 W. Act. Piston Adjustment Screw & Housing Only	527-100-020	1
-	Actuator Assy. Repair Kit (Includes Items 4 thru 18)	560-001-130	1
22	Switch Assy. - Electric Lube Sentry (Includes Items 23 thru 32)	527-100-170	1
23	Switch Enclosure Screw	503-680-000	1
24	Microswitch Assy.	527-100-210	1
25	Nylon Ball 5/32"	504-706-000	1
26	Setscrew No. 10-32 x 3/8" lg.	417-450-040	1
27	Round Head Screw	416-010-070	2
28	Int. Lockwasher	421-070-010	2
29	Socket Head Screw 1/4-20 x 1 3/4	419-130-090	4
-	Electric Switch Assy. Repair Kit (Includes Items 23 thru 29)	560-001-120	1
30	Switch Housing	527-100-090	1
31	Adaptor	503-681-000	1
32	Conduit Elbow w/nipple	507-912-000	1
22	Valve Assy. - Pneumatic Lube Sentry (Includes Items 23 thru 32)	527-100-150	1
23	O-Ring 70 Duro	422-041-200	1
24	O-Ring 70 Duro	422-040-220	1
25	Air Valve Spring	503-658-000	1
26	Valve Cartridge	503-659-000	1
27	Spring Guide	527-100-320	1
28	Socket Head Screw 1/4-20 x 1 3/4	419-130-090	4
-	Pneumatic Lube Sentry Repair Kit (Includes Items 23 thru 28)	560-001-110	1
29	Air Valve Housing	527-100-070	1
30	Air Valve Enclosure Screw	527-100-080	1

SPECIFICATIONS

Material	Steel
Max. Pressure	6,000 psi (41,370 kPa)
(1) Flow rate (per day) Max.	400 pints (189.2 liters)
Min.	4 pints (1.89 liters)
Pressure Drop	250 psi (1,725 kPa)
Seals	Viton*
(1) Lubricant	Oil (450 to 2,000 SUS)
Net Weight	5 lbs. (2.265 Kg)
Operating temperature	-20 to 180 °F (-29 to 82 °C)
Air Pressure (Max.)(Pneumatic Lube Sentry)	125 psi (862 kPa)
Electrical Rating:	1) 5 amps @ 125/250 VAC
	2) A, B, or C @ 28 VDC
	A - Inductive -3 AMP
	B - Resistive -5 AMP
	C - Max. Inrush -15 AMP
(1) Reference Graph No.	1

* Registered trademark of DuPont Company



© Registered trademark of LUBRIQUIP, INC., A Unit of IDEX Corporation, Printed in U.S.A.

