

PR3 SERIES

2 - 15 PSIG RELIEF



VACUUM TIGHT PRESSURE RELIEF DISCS



Features

- Vacuum Tight Seal
- Full 360° Pressure Outlet
- Low Pressure Relief
- Stainless Steel Construction
- Compact Design
- Adjustable Relief Option

Applications

- Protection of Outer Wall for High Vacuum Containers
- Pressure Equalization for Volume Chambers
- Relief Valve for Vacuum Insulated Piping Systems
- Breather Valves for Storage Tank Vents

Options

- Adjustable Relief Pressure
- Available up to 15 PSIG

Technical Data

Operating Ranges

Temperature	-20°F to +150°F; (-29°C to +66°C)
Relief Pressure	2 to 15 PSIG (.14 to 1.04 BAR)

Materials of Construction

Body	300 Series S/S or 6061 Aluminum
O-Ring	Viton®
Poppet	300 Series Stainless Steel
Spring	300 Series Stainless Steel
Hardware	300 Series Stainless Steel

Tests

Seat Leakage	Mass spec. less than 1×10^{-9} scc GHe/sec (Exclusive of O-ring Permeability) at Ambient Temp.
--------------------	---

Connection

Welded or Threaded

Valve Size

1/2" to 3"

PR3 SERIES

2 to 15 PSIG RELIEF

How To Order

PR3 - 084 - 5 T2 - HP3

BASIC MODEL NUMBER

PR3 Series

VALVE SIZE

- 084 - 1/2"
- 086 - 3/4"
- 088 - 1"
- 812 - 1-1/2"
- 816 - 2"
- 820 - 2-1/2"
- 824 - 3"

CONSTRUCTION

- 5 - 300 Series Stainless Steel
- 1 - 6061 Aluminum

CONFIGURATION

- T2 - Threaded Connection (1/2" - 1")
- F2 - Flanged Connection (1-1/2" - 3")
- W2 - Welded Connection

RELIEF SET

Blank - 2-6 PSIG Standard

Adjustable Relief Set Options:

- HP3 - 3 PSIG
- HP4 - 4 PSIG
- HP5 - 5 PSIG
- HP6 - 6 PSIG
- HP7 - 7 PSIG
- HP8 - 8 PSIG
- HP9 - 9 PSIG
- HP10 - 10 PSIG
- HP11 - 11 PSIG
- HP12 - 12 PSIG
- HP13 - 13 PSIG
- HP14 - 14 PSIG
- HP15 - 15 PSIG

Dimensions

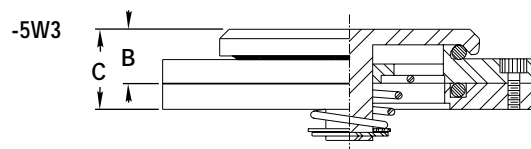
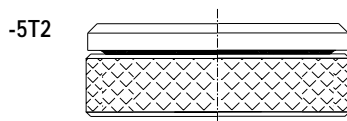
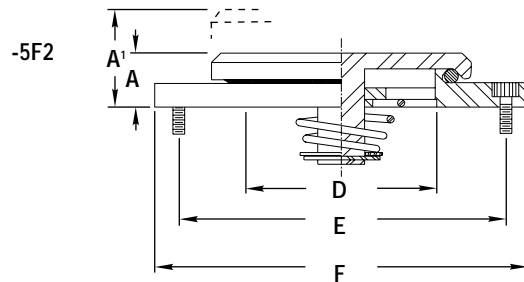
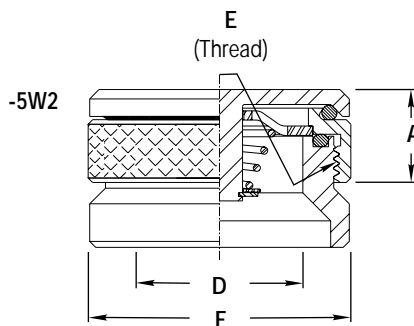

Part No.	A	A'	B	C	D	E	F
PR3-084	.50	.75	.75	.88	.69	1.06.16	1.19
PR3-086	.50	.75	.63	1.13	.94	1.38.16	1.50
PR3-088	.63	.94	.75	1.13	1.19	1.63.16	1.75
PR3-812	.56	.75	.31	.88	1.63	2.38	2.75
PR3-816	.56	.88	.31	.88	2.13	2.94	3.25
PR3-820	.69	1.00	.44	1.13	2.69	3.50	4.00
PR3-824	1.13	1.25	.50	1.63	3.38	4.38	5.00