

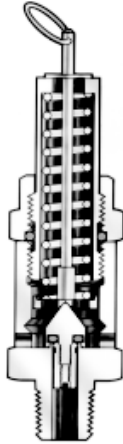

**D500 Series 15 to 150 PSIG**  
**M5100 Series 20 to 1200 PSIG**  
**ASME Safety Relief Valves**

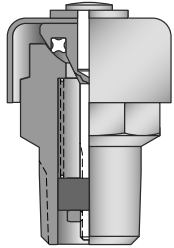

**Features**

- D500 Features Cap Design
- M5100 Offered with Ring or Lift Handle

**Technical Data**

ASME	<ul style="list-style-type: none"> <li>• American Society of Mechanical Engineers</li> </ul>
Body Construction Materials:	<ul style="list-style-type: none"> <li>• D500 – Naval Brass or 316 Stainless Steel</li> <li>• M5100 – Naval Brass or 316 Stainless Steel</li> </ul>
O-ring Materials:	<ul style="list-style-type: none"> <li>• D500/M5100 – Buna N, Neoprene, Teflon® or Viton®</li> <li>• D500 – Ethylene Propylene, and Silicone</li> </ul>
Set Pressure:	<ul style="list-style-type: none"> <li>• D500 – 15 to 150 PSIG 1/4"</li> <li>• M5100 – 20 to 1,200 PSIG 1/8", 3/4", 1" 50 to 1,200 PSIG 1/4", 3/8", 1/2"</li> </ul>
Temperature Range:	<ul style="list-style-type: none"> <li>• -100° F to +400° F (-73° C to 204° C) Based on o-ring material, see "How to Order"</li> </ul>
Connection Sizes:	<ul style="list-style-type: none"> <li>• D500 – 1/4" Male Pipe</li> <li>• M5100 – 1/8" to 1" Male Pipe</li> </ul>

**Terminology For ASME Safety Relief Valves**

**SAFETY RELIEF VALVES**

An automatic pressure relieving device actuated by the static pressure upstream of the valve, which opens in proportion to the increase in pressure over the opening pressure.

**START-TO-LEAK PRESSURE**

The pressure at the valve inlet where the relieved fluid is first detected (on the down-stream side of the seat) before normal relieving action takes place.

**OPENING PRESSURE (SET PRESSURE)**

The valve inlet pop point pressure at which there is a measurable lift or discharge becomes continuous as determined by seeing, hearing or feeling. In the pop type of safety valve, it is the inlet pressure at which the valve opens, allowing a larger amount of fluid as compared with corresponding valve movements at higher or lower pressures.

NOTE: A safety relief valve is not considered to open when it is simmering at a pressure just below the popping point even though the simmering may be audible. This set pressure distinguishes our ASME relief valves from our standard relief valves whose cracking pressure indicates initial flow.

**RELIEVING PRESSURE**

(Opening Pressure plus Overpressure) The pressure measured at the valve inlet at which the relieving capacity is determined.

**CLOSING PRESSURE**

(Reset Pressure) The pressure measured at the valve inlet, at which the valve closes, flow is substantially shut off, and there is no measurable lift.

**SEAL-OFF PRESSURE**

The pressure (measured at the valve inlet) after closing at which no further gas is detected at the down-stream side of the seat.

**OPERATING PRESSURE**

The actual pressure at which a vessel is maintained in normal operation.

**ACCUMULATION**

Pressure build-up or overpressure beyond the set pressure of a safety relief valve, at which capacity flow is rated. Capacities are usually based on 10% accumulation.

NOTE: Proper filtration is recommended to prevent damage to sealing surfaces.

**D500 Series 15 to 150 PSIG**  
**M5100 Series 20 to 1200 PSIG**  
**ASME Safety Relief Valves**

**Flow Curve D500 Series ASME Safety Relief Valve**

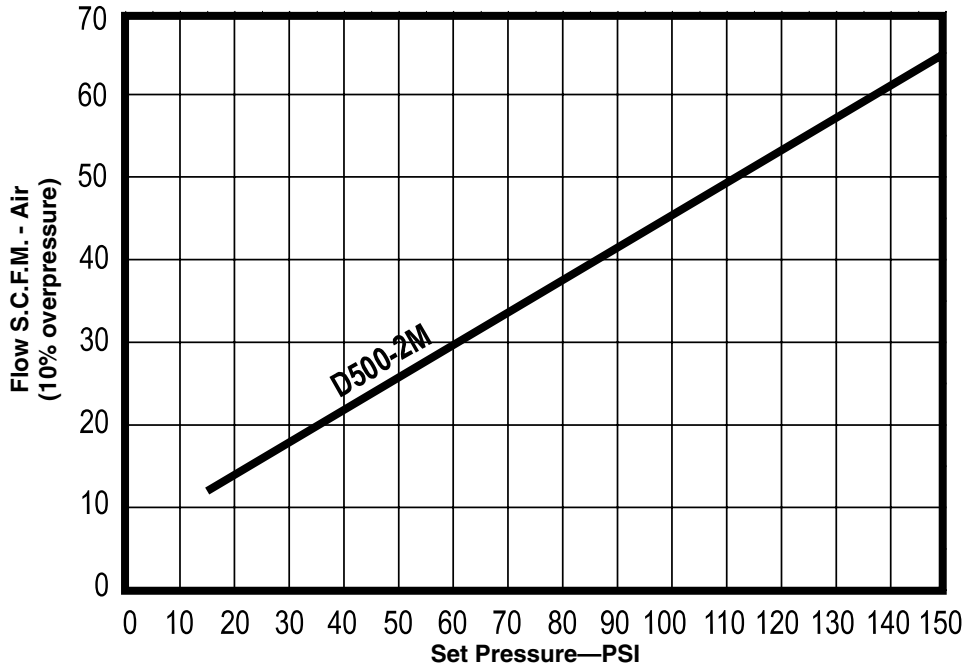

**Flow Curve M5100 Series ASME Safety Relief Valve**

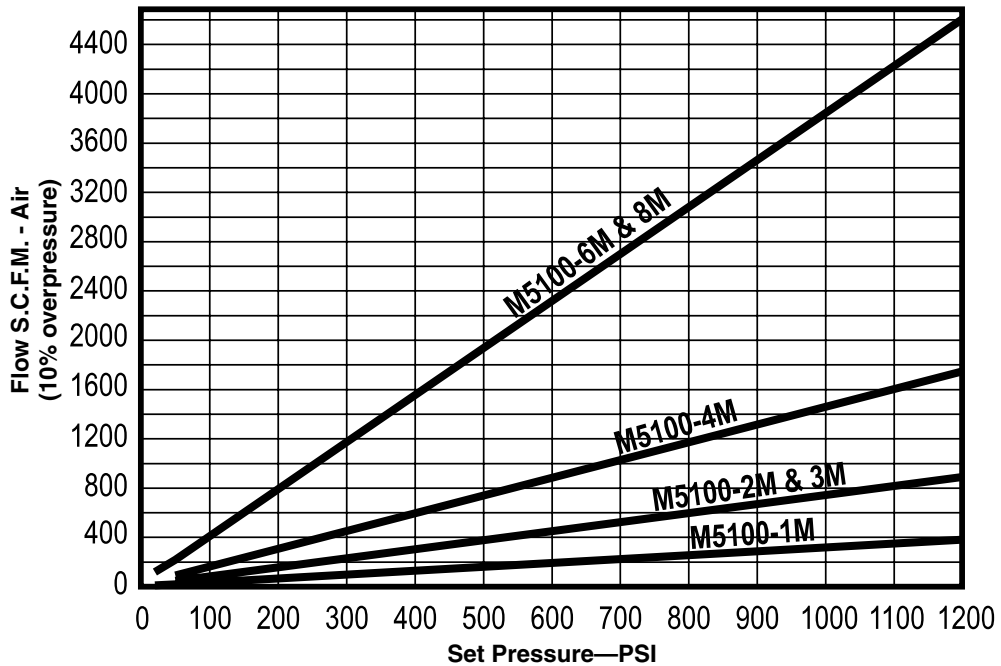

# D500 Series 15 to 150 PSIG

# M5100 Series 20 to 1200 PSIG

## ASME Safety Relief Valves

### How to Order

### D500 Series ASME Safety Relief Valve—15 to 150 PSI

**D5 32 T1 - 2 M - 20**

**BASIC MODEL NUMBER**  
D500 Series

**O-RING MATERIAL & TEMPERATURE**

- 59 - Buna N            -40° F to +250° F
- 62 - Ethylene  
Propylene            -20° F to +250° F
- 33 - Neoprene        -20° F to +240° F
- 24 - Silicone         -65° F to +150° F
- 20 - Teflon®         -100° F to +400° F
- 32 - Viton®           -20° F to +350° F

**CRACKING PRESSURE**  
Specify set pressure in PSIG  
20 - 20 PSIG

**CONNECTIONS - Inlet**  
M - Male Pipe

**VALVE SIZE**  
2 - 1/4"

**MATERIAL & OTHER PRESSURE BOUNDRY COMPONENTS**

- N - Naval Brass
- T1- 316 Stainless Steel

**Notes:**

Teflon® and Viton® are registered trademarks of Dupont.

Please consult your Circle Seal Controls Distributor or our factory for information on special connections, lubricants, operating pressures and temperature ranges.

### Dimensions (Inches)

Dash No.	Size	A	B Hex	C Dia
2M	1/4"	1.375	.625	.90

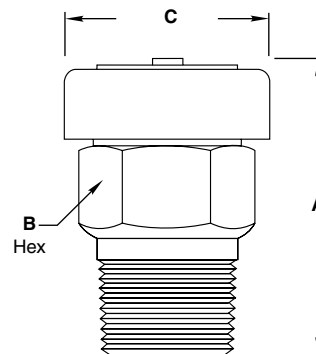

### Recommended Installation

- 1 Before installing a new safety relief valve, we recommend that a pipe tap be used to assure clean-cut and uniform threads in the vessel opening and to allow for normal hand engagement followed by a half to one turn by wrench.
- 2 Avoid over-tightening as this can distort the valve seat.
- 3 Avoid excess "popping" of the valve. Safety relief valves should only be operated often enough to assure they are in good working order.
- 4 Apply only a moderate amount of pipe compound or tape to the threads, leaving the first thread clean parts.
- 5 Don't oversize the valve, as this may cause chatter resulting in rapid wear of the moving parts.
- 6 Avoid wire, cable or chain pulls for attachments to levers that do not allow a vertical pull. The weight of these devices should not be applied to the safety relief valve.
- 7 Avoid having the operation pressure too near the valve set pressure. A minimum differential of 10% is recommended.

**For Your Safety**

*It is the sole responsibility of the system designer and user to select products suitable for their specific application requirements and to ensure proper installation, operation and maintenance of these products. Material compatibility product ratings and application details should be considered in the selection. Improper selection or use of products described here in can cause personal injury or property damage.*

# D500 Series 15 to 150 PSIG

# M5100 Series 20 to 1200 PSIG

## ASME Safety Relief Valves

### How to Order

### M5100 Series ASME Relief Valves—20 to 1200 PSIG

**M51 59 N - 4 M(L) - 20**

**BASIC MODEL NUMBER**

M5100 Series

**O-RING MATERIAL & TEMPERATURE**

- 59 - Buna N -40° F to +250° F
- 33 - Neoprene -40° F to +250° F
- 20 - Teflon® -100° F to +300° F
- 32 - Viton® -20° F to +400° F

**Notes:**

\*Set Pressure – 20 to 1200 psi – 1/8", 3/4", 1"  
50 to 1200 psi – 1/4", 3/8", 1/2"

Teflon® and Viton® are registered trademarks of Dupont.

Please consult your Circle Seal Controls Distributor or our factory for information on special connections, lubricants, operating pressures and temperature ranges.

**CRACKING PRESSURE**

Specify Set Pressure in PSIG\*  
20 - 20 PSIG

**CONNECTIONS - Inlet**

- M - Male Pipe
- (L) - Lockwire

**VALVE SIZE**

Pipe Sizes in 1/8" Increments  
1 - 1/8" 2 - 1/4" 3 - 3/8"  
4 - 1/2" 6 - 3/4" 8 - 1"

**BODY CONSTRUCTION MATERIALS**

- N - Naval Brass
- T1 - 316 Stainless Steel

### Dimensions (Inches)

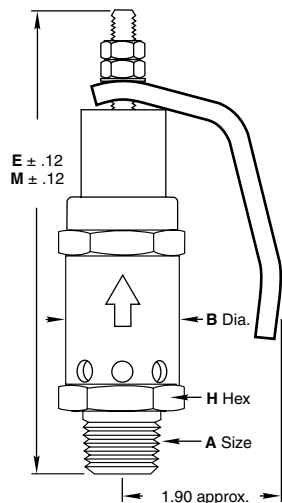

Dash No.	A Size	E	M	B Dia H Hex
1M	1/8"	2.84	3.70	.81
2M	1/4"	3.16	4.50	1.00
3M	3/8"	3.19	4.53	1.00
4M	1/2"	3.86	6.16	1.25
6M	3/4"	5.41	9.08	1.50
8M	1"	5.59	9.26	1.50

**Lift Handle**  
For 1/2", 3/4" and 1" valve sizes with set pressure of 451-1200 psi

**Ring Handle**  
For set pressures to a maximum of 1200 psi in 1/8" through 3/8" valve sizes to a maximum of 450 psi in 1/2" through 1" sizes

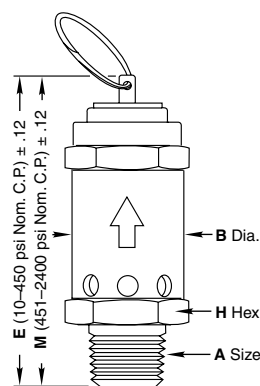

### Important

Complete part number MUST INCLUDE Set Pressure in PSI. The ASME requires that valves be set at a "pop point." The ASME refers to this as the Set Pressure. This point is higher than the traditional Circle Seal Controls definition of cracking pressure.

After a prolonged period of storage with no system pressure, these relief valves will evidence an apparent high set pressure on first pop; therefore, in receiving inspection tests, true Set Pressure should be determined after first pop.

The following Circle Seal Controls valves have been tested in accordance with procedures in Paragraph UG 131, Section V111 of the ASME Unified Pressure Vessel Code:

- D500-2M
- M5100-1M(L)
- M5100-3M(L)
- M5100-6M(L)
- M5100-2M(L)
- M5100-4M(L)
- M5100-8M(L)

ASME Certificate of Authorization, Number 4599

**Note: These valves are not certified for steam and liquid service.**